

WhisperPower Book #1

Supersilenced Marine Generators

Commercial Marine



Recreational Marine



Offshore



Enjoy Green Energy







whisperpower.com



The certainty of non-stop onboard power
Anywhere, any time,
 under the most challenging conditions



Index | Contents

Generating Power	 AC	Piccolo Series - AC output	120 / 230 VAC	8	Piccolo - AC
	 Twin Power	Piccolo Twin Power - AC output	120 / 230 VAC	30	Piccolo - Twin
	 DC	Piccolo Series - DC output	24 / 48 VDC	35	Piccolo - DC
Generate	 M-SQ Series	M-SQ Series	1500 / 1800 rpm	48	M-SQ
Install	 Installation Parts	Installation Parts	<ul style="list-style-type: none"> • Silencer/Waterlock • Water-Gas Separator • Hoses • Cables 	62	Installation Parts
Control	 Monitoring	Monitoring	<ul style="list-style-type: none"> • Genverter control • DDC remote control • DeepSea Control • WhisperTouch 	66	Monitoring
General	 Service & Support	Service & Support		68	Service

The information contained in this catalogue is for general information purposes only. While we endeavour to keep the information up to date and correct, we cannot be held responsible for alterations of specifications of products over time.

Generating Power | the WhisperPower approach Smaller, lighter, quieter and cleaner

WhisperPower is an innovative company committed to providing the best solutions for grid-independent marine, mobile and offgrid power systems. We manufacture compact and supersilent generators that comply with the most stringent emission norms (Stage V for Europe, EPA Tier 4 for North America).

Our Genverter inverter based adjustable speed generators are internationally recognized as the most fuel efficient, compact and silent solution to provide on board power. With an extreme accurate output power quality at either 230 VAC 50/60 Hz or 120 VAC 60 Hz. Our 1500/1800 rpm style generators are the best in it's class, offering super silent non-stop power to all on board single or three phase appliance .

Stage V / EPA certified

On board power systems are in general not very efficient because generators are often partially loaded, over dimensioned and not equipped with engines that meet current emission standards such as Stage V or EPA tier 4 for USA. Regulations regarding diesel generators for mobile use are becoming more stringer. Not only the emission standard (Stage V is a must) but also the noise level is a central theme.

One-stop-shop

WhisperPower is your one-stop shop for the entire system including all necessary electrical components. The WhisperPower adviser, reseller or installer provides, from the outset, system advice demonstrated on a schematic in which all components are included.

Once ordered and delivered, systems equipped with an inverter, charger system, battery and a diesel generator are inspected and commissioned ensuring you are assured of a well-functioning system with no weak links.

Hybryde variants

We have developed a solution against wasting energy which is cost saving at the same time: our OctoPower range of low-to-zero emission power systems are smart, integrated power systems for yachts and commercial craft that include battery/ inverter power provision.

Explore our website and discover our extended range of OctoPower products and systems. www.whisperpower.com.

Diagnostics (WhisperCare)

The integration of these various technical systems in to the WhisperPower monitoring and control system enables streamlined and efficient monitoring with one panel. WhisperCare enables remote login to the WhisperPower system with smart phone, tablet or PC over a WiFi/ router package with SIM card, available as an option for a WhisperPower system.

Service & support on location

The representatives in our network will provide you with service and technical support in case of repairs or malfunctions. Where possible they will help you on site, wherever you may be in the world. Your nearest dealer can be found on our dealer locator which is available on our website.

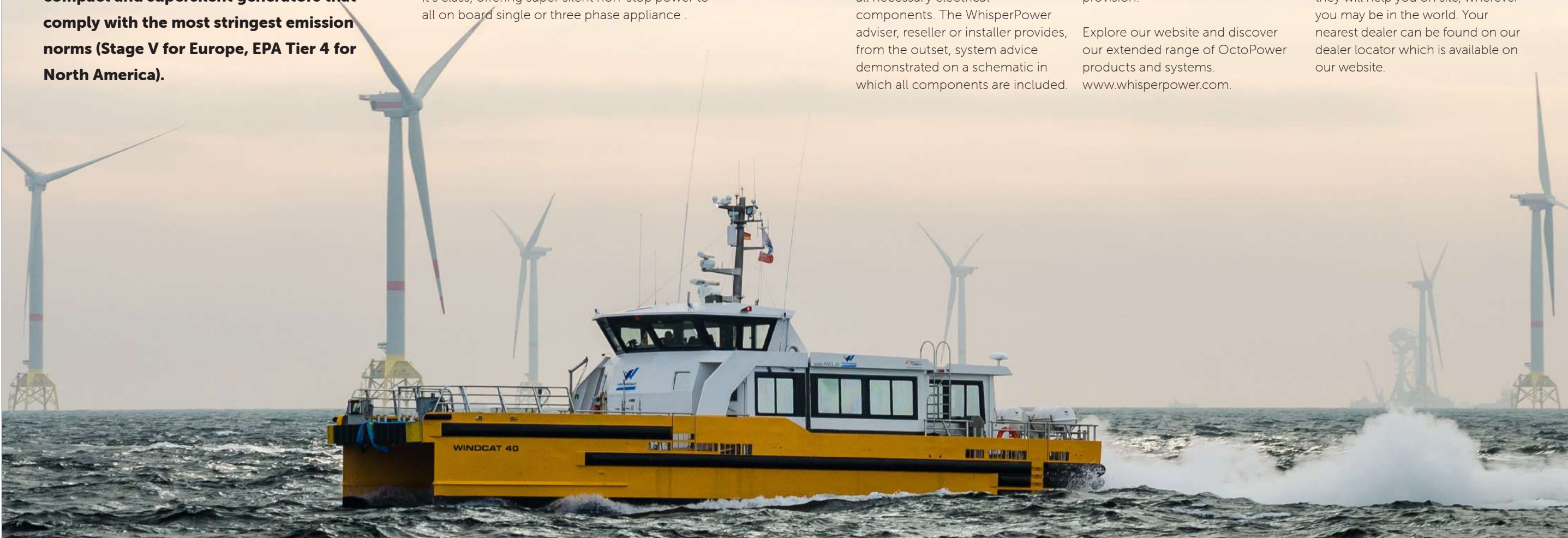

- International
- Benelux
- Germany
- United Kingdom
- Spain & Portugal
- China
- Pacific
- Americas



whisperpower.com/where-to-buy





Super Compact & Low Weight

From 4.4-18 (Twin 12-36) kVA Choose your power window

Our Genverter® range of compact generators combines the latest diesel engine technology with a new way of producing electrical power. Instead of adding an alternator with fixed speed on the back of the fly-wheel, we have designed a very compact permanent magnet alternator (PM), located just behind the engine. As a result, these systems are much smaller and lighter compared to traditional generators. The generator RPM can be fixed to a position offering the optimal balance between RPM, output power, audible noise and vibration.

Advanced Power Systems



System Configuration

Key Components

ADJUSTABLE
SPEED

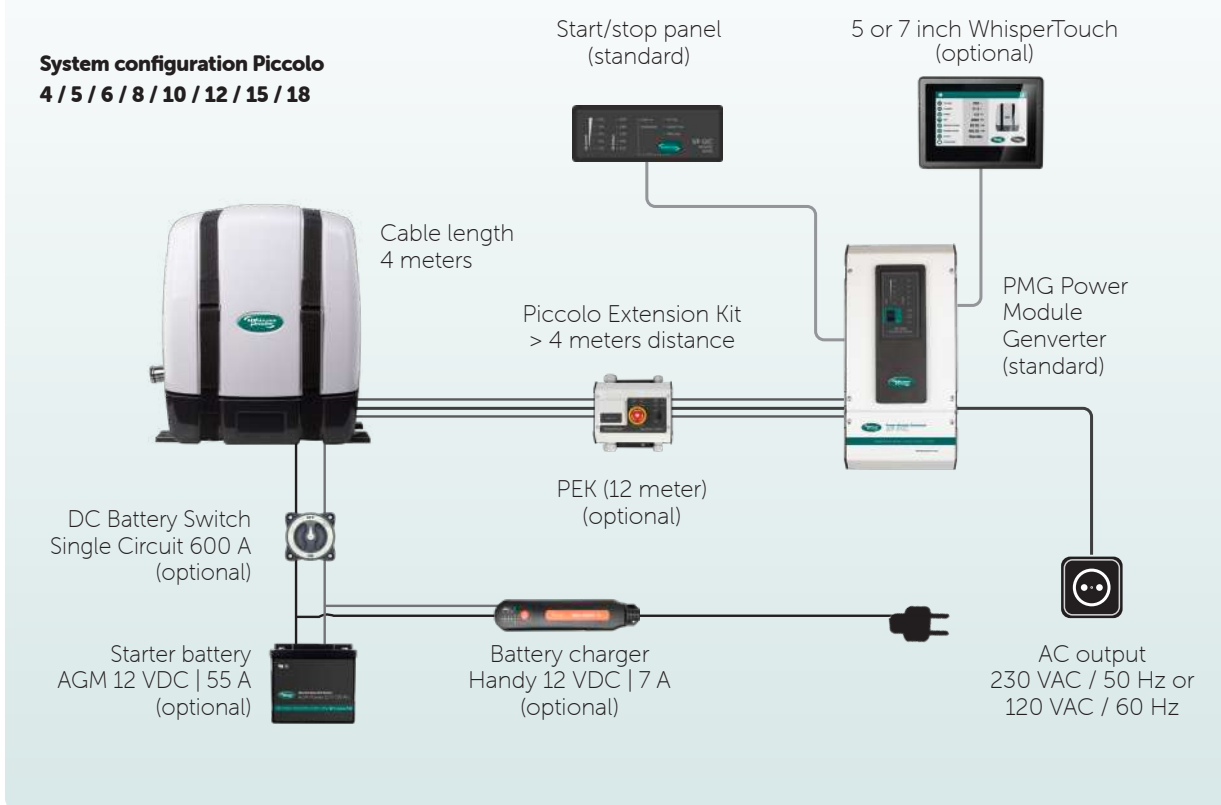

Genverter

Essential accessories



All Piccolo models are delivered as standard with a comprehensive start/stop remote control panel and 6 meters of connection cable with telejack connectors. 5, 7 or 10 inch WhisperTouch panels are optional.

PMG inverter with professional terminal connections for cables in/out and communication incl. CAN.

WP Starter battery installation kit < 100 Ah. Art. Nr. 40290106



Genverter® Piccolo 4/5 | 1 cylinder

The little power house

ADJUSTABLE
SPEED

The WhisperPower Genverter® Piccolo 4 & 5 are the smallest, quietest and most powerful of its kind. Thanks to the electronic PMG inverter output, it delivers the ideal power quality for all your comfort equipment including, amongst others, washing machine, air conditioning, electrical cooking, hob, battery chargers and combi's.



Piccolo 4/5 Adjustable speed diesel generator

- 4.4 kVA / 3.5 kW at 3600 rpm
- 8 kVA, 36 A peak power
- 230 VAC - 50 Hz $\pm 5\%$ 50 Hz $\pm 0.1\%$
- 117 VAC - 60 Hz $\pm 5\%$ 60 Hz $\pm 0.1\%$
- Height 520 mm, width 470 mm
- Length 450 mm, weight 68 kg
- PMG inverter 7.6 kg

Compact and light - 68 kg

- Modern diesel engine with 4.4 kVA capacity at 3600 rpm
- 4kW electric capacity at maximum speed
- Indirect water cooling - for fresh or sea water
- Constant engine temperature, no soot or oil deposit on the water
- Flywheel and alternator functions combined

Advanced

- Highly efficient thanks to use of super magnets / permanent magnet technology
- Adjustable speed settings - optimal position can be set
- Optional Automatic Speed Control
- PowerModule-Genverter® in the output ensures perfectly stable frequency and voltage
- Therefore smooth operation of all connected devices is guaranteed

Advanced

- Standard Versions for 230 VAC 50 Hz (100-120 VAC 50/60 Hz) devices
- Adjustable to 60 Hz, without effecting rpm
- Available with complete Touch screen power management & monitoring
- WhisperConnect bus connectivity to most navigation brands

From Glenn Doncaster, Virginia, USA:

"After replacing two other generators in my previous boat, I'm delighted with the variable speed nature of the Piccolo 4 installed in my new Arcona 465 Carbon. Because it's been paired with a lithium battery system, I can constantly keep my air conditioning on and only start the generator when I need to charge. Weight is also significant since I use the boat for long-distance offshore racing."

"The Piccolo efficiently delivers 3.5 kW and only weighs 150 lbs. The noise and vibrations are minimal too. I'm very pleased all around."



Unique engine

The small Piccolo 4/5 models are fitted with a modern diesel designed by WhisperPower, entirely for the purpose of generating power the smooth way. The oil is cooled by a heat exchanger designed for indirect watercooling, the circulation water pump is driven by a PTO (no belt). The WP1 engine is designed to operate between 2400 and 3600 rpm. Warranty 1000 hrs, equivalent to a car distance of 100.000 km.



Highest power quality

Devices such as air conditioning units and electric motors are often controlled by electronics to improve the efficiency and performance. Traditional generators may fail to operate these appliances. All Piccolo models are equipped with a PMG module (Power Module Genverter®) to ensure that the voltage and frequency within the rotating speed range remain perfect so that all the equipment continues to run without interruption. Surge power is generated by the PMG to start up inductive loads.



Quiet & vibration free

Vibrations are just as irritating as an over noisy diesel engine. The customized shock mounts, combined with the sound enclosure, result in a super silent and virtually vibration free set-up. All parts needed to be serviced are located at one side of the Genverter. Picture: detail of our WhisperPower WP 1 diesel engine (Shockmount integrated in engine block).



Complete energy system

This is our great service to you as our customer: we offer complete single brand solutions for the complete on board electrical power system. Everything from one hand. If needed supplied with DC distribution/digital switching, our TOUCH Plus system.



Ease of installation

All installation parts are available in kit form ensuring an fast and easy job to do. Not a single part or component is needed, all are included.



Any space will do

All our Piccolo models are extremely compact and can be installed in the smallest location. Only minor air ventilation is needed. At picture an installation of a Piccolo 5 in a day cruiser



Genverter Piccolo 4 Piccolo 5



Available variations:

230 VAC | 4.4 kVA | 3.5 kW | 50 Hz
120 VAC | 3.5 kVA | 3.5 kW | 60 Hz

Dimensions Piccolo 4/5

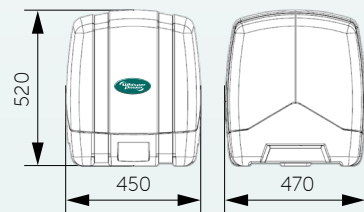

PMG included



Genverter control included



3.5 kVA
4.4 kVA

	PICCOLO 4 120 VAC / 60 Hz	PICCOLO 5 230 VAC / 50 Hz
	49002055	49003005
	49002056 - Ungrounded	49003006 - Ungrounded
	49012055 - Variable speed	49013005 - Variable speed
	49012056 - Variable speed/ Ungrounded	49013006 - Variable speed/ Ungrounded

MAIN SPECIFICATIONS

Intermittent Power kW at 25°C (77°F)	3.5 kW	3.5 kW
Continuous Power kVA at 25°C (77°F)	3.5 kVA	4.4 kVA
Continuous Power kW at 25°C (77°F)	3 kW	3 kW
Noise level	54 dB(A) at 7 m, 65 dB(A) at 1 m	54 dB(A) at 7 m, 65 dB(A) at 1 m
RPM range	2400 .. 3600 rpm, adjustable	2400 .. 3600 rpm, adjustable or automatic
Alternator technology	Permanent Magnet	Permanent Magnet
Generator cooling	Air cooled	Air cooled
Generator control	PMG	PMG
Control Panel	PMG + PMG Remote	PMG + PMG Remote
Inverter Module	PMG frame 1	PMG frame 1
Nominal voltage / frequency	120 VAC, 50 / 60 Hz	230 VAC, 50 / 60 Hz
Phase/wire	1 phase, 3 wires	1 phase, 3 wires
Peak power 2 s	200%	200%
Harmonic distortion	< 5%	< 5%
Frequency tolerance	± 0,1%	± 0,1%

DIESEL ENGINE SPECIFICATIONS

Engine	WP1	WP1
Displacement	309 cc	309 cc
Cylinders	1	1
Bore & stroke	78 x 67 mm	78 x 67 mm
Compression ratio	21.1	21.1
Air consumption	< 0.42 m ³ /min	< 0.42 m ³ /min
Cooling system	Heat exchanger	Heat exchanger
Fuel consumption (no load - full load)	0.8-1.2 l/hr	0.8-1.2 l/hr
Starter battery charge method/ current	Handy charger 12 VDC / 7 A	Handy charger 12 VDC / 7 A

DIMENSIONS & WEIGHT

Length x width x height (cabinet) mm (in.)	450 x 470 x 520 (17.7 x 18.5 x 20.5)	450 x 470 x 520 (17.7 x 18.5 x 20.5)
Length x width x depth (PMG) mm (in.)	420 x 196 x 148 (17.1 x 7.7 x 5.8)	420 x 196 x 148 (17.1 x 7.7 x 5.8)
Dry weight (cabinet + PMG)	68 kg + 7.6 kg	68 kg + 7.6 kg
Exhaust type	Ø 40 mm, wet	Ø 40 mm, wet
Max. operating angle	25° in all directions	25° in all directions

OPTIONAL

	Touch panel, PEK (Piccolo extension kit)	Touch panel, PEK (Piccolo extension kit)
	Ungrounded	Ungrounded



ACCESSORIES & OPTIONS FOR PICCOLO 4/5	
Article number	Definition
40280105	WhisperTouch 5" - Piccolo/Scalino Genverter operation *)
40230201	Water inlet kit 12.5 mm (1/2")
40230272	Syphon breaker kit 12.5 mm (1/2")
40230281	Waterlock exhaust kit 40 mm (1 5/8")
40230291	Water/Gas separator kit 40/40/40 (1 5/8")
40230208	Base plate kit aluminium (W x D x H) 600 x 400 x 20 mm
40290060	Starter battery - AGM Power 12 VDC 55 Ah (will be charged by Genverter when running)
40290106	Starter battery installation kit incl. Battery Charger - Handy 12 VDC 7 A (recommended for temporary laying)
40230205	Universal fuel kit

*) WhisperTouch 5" is optional



EXTRA ACCESSORIES FOR PICCOLO 4/5	
Article number	Definition
4022244	WPL-15W40 General, Lubricant oil, 4 liters 1 container required
40401170	A-kit maintenance parts
40401171	B-kit maintenance parts
60201470	Piccolo Extension Kit (12 m), to be mounted between the PMG and Piccolo *)

*) Standard cable length between Piccolo an PMG is 4 meter

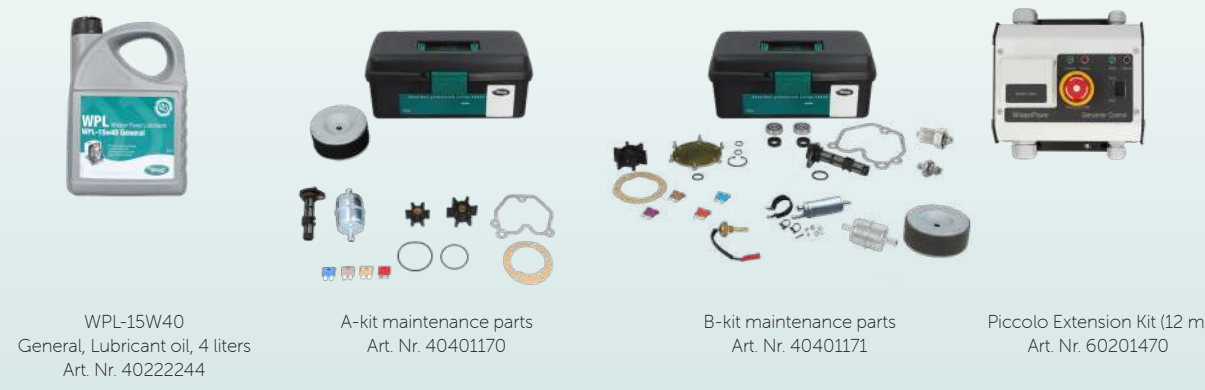



Genverter® Piccolo Range | 2/3/4 cylinder Little ones grow bigger

ADJUSTABLE
SPEED

Following the world wide success of the Piccolo 4/5, 1 cylinder Genverter variable speed generator, we have extended our Piccolo range to power ratings of 15 kVA. Perfect in size and weight, super silent and virtually vibration free.

Compact, silent and light weight

- Modern, low emission marine diesel engine
- Emission level: Stage V, EPA – Tier 4 as standard
- Compact, super noise-damping polyester sound guard
- Available power ratings 6, 8, 10, 12 15 and 18 kVA
- 230 VAC 50 Hz or 120 VAC 60 Hz, adjustable by user.

Extremely energy efficient

- Efficiency of 96% instead of 75% (traditional systems)
- Lower fuel costs
- Rotating speed can be set to load demand
- External PMG inverter providing the perfect sine wave
- Maximum stability of the Hz at load/ no load and rpm variations

Choose from AC or DC variations

- AC single phase with PMG inverter
- DC versions with 1,2 or 3 DC PowerCubes
- Charge power for (lithium) batteries via DC PowerCube
- DC-system includes shore to ship charging
- Charge power from 4.3 kW – 13 kW



Essential Remote Communication

WhisperConnect for linking with other devices and USB interface for eventual uploads. Analogue remote controls and cables supplied as standard, digital Touch panels are optional.



Supplied as standard with DDC panel and DDC connection box



Optional TOUCH 5 or 7 control panel with extended information and remote access

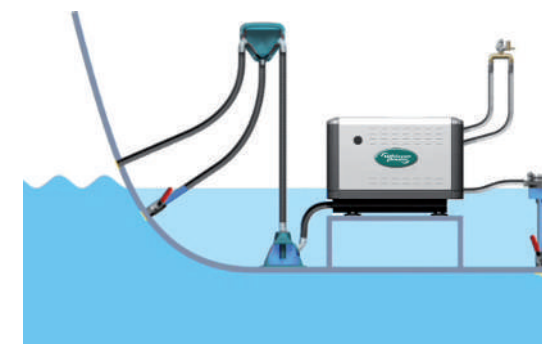

Optimal sound and vibration control

A robust polyester sound guard, optimal tuning of rpm vs power rating and effective engine mounting inside the enclosure result in a audible noise level of less than 55 dBA and virtually no vibration.

One-stop-shop

We provide high class parts to install the Piccolo the right way: exhaust hoses with waterlock and water/gas silencer complete with clems, a water inlet kit with strainer, a siphon breaker kit, a fuel filter, a starter battery kit etc.



Perfect power

WhisperPower's PMG inverter incorporates two main functions: this robust, electronic device converts the generated power (input) into a pure sine wave with fixed Hz (output). The rotating speed is programmable from 2000 to 2800 rpm, select the rotating speed for the needed power. The PMG power inverter is also the power management device, offering full read-out via WhisperConnect to the Touch panel. Voltage and frequencies can be selected.



Low emission, water cooled engine

Only the best 2, 3 and 4 cylinder engines are applied: long lasting, reliable, silent engines, complying with EPA /Tier 4 (USA standard) and Stage V (European standard). The engine and PM alternator back-end are connected into one cooling circuit and kept on a constant temperature via a heat exchanger.



Ideal for A/C systems

All Piccolo models including the little Piccolo 5 are a perfect power source for air-conditioning systems. We recommend Self Contained systems as they are compact, silent and energy efficient.



Piccolo 8



OctoPower system

Turn it around! Install a high power inverter for all your AC consumers and a small Genverter generator, instead of installing a large genset and a small inverter. Use the energy storage as your power reservoir and enjoy extended zero emission & silent periods.



Genverter Piccolo 6



Available variations:

230 VAC | 6 kVA | 6 kW | 50 Hz
120 VAC | 6 kVA | 6 kW | 60 Hz

Dimensions Piccolo 6

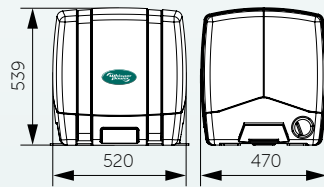

PMG included



Genverter control included



6 kVA

PICCOLO 6

Genverter based on
Kubota Z482-E4B

System output	6 kVA / 6 kW
Peak power 200msec	200%
RPM range	2500 .. 2800 rpm
Low rpm setpoint	1800 rpm
Max rpm setpoint	3200 rpm
Typical rpm	2400 .. 2600 rpm
Sound level @ 7m	51 dBA
Sound level @ 1m	60 dBA
Cooling	Intercooling
Exhaust	Wet type, 40 mm (except ..030)
Speed governor	Mechanical
Starter battery capacity	12 VDC / 80 Ah
Standard supplies	fuel filter, fuel lift pump, user and installation manuals (models featuring DDC: digital remote panel, 10 m cable)

Available options installation kits, non-earth return (ungrounded), spare part kit, longer or shorter DDC cables

MECHANICAL SPECIFICATIONS

Dimensions (l x w x h)	520 x 470 x 541 mm
Dry weight incl. sound shield	145 kg [keel-cooled: 147 kg]
PMG dimensions (h x w x d)	420 x 196 x 148 mm
PMG weight	7.6 kg (230 VAC) 9.9 kg (120 VAC)
Color	RAL9010 signal white, RAL9020 metallic black

ENGINE

Engine model	Kubota Z482-E4B
Emission Regulation	Tier 4, EPA
Engine performance intermittent SAE J1349	8.3 kW @ 3000 rpm
Engine performance continuous SAE J1349	7.4 kW @ 3000 rpm
Number of cylinders	2
Displacement	0.479 l
Bore & stroke	67 x 68 mm
Air intake system	Naturally aspirated
Air consumption	< 0.63 m ³ /min
Fuel oil	Diesel fuel oil (ASTM No. 2-D)
Fuel consumption @ full load	275 g/kWh
Engine cooling	Indirect water cooled (keel-cooling closed)
Alternator	12.5 A
Operating principle	Energize to run
Starter power requirement	0.8 kW
Nominal operation voltage	12 VDC
Monitoring and control	ECU in Power Module
Protections	Oil temperature and pressure, exhaust/coolant temperature [dry/wet exhaust]
Local control	PMG only
Service interval oil change	200 h
Lubricant	At least CF
Oil capacity	Approx. 2.1 l



WhisperTouch 7" Art. Nr. 40280101 | Water inlet kit 20 mm (3/4") Art. Nr. 40230211 | Syphon breaker kit 20 mm (3/4") Art. Nr. 40230273 | Water lock exhaust kit 40 mm (1 1/8") Art. Nr. 40230281 | Water/Gas separator kit 40/40/40 (1 1/8") Art. Nr. 40230291

ACCESSORIES & OPTIONS FOR PICCOLO 6

Article number	Definition
40280101	WhisperTouch 7" (system panel) connection cable included *)
40230211	Water inlet kit 20 mm (3/4")
40230273	Syphon breaker kit 20 mm (3/4")
40230281	Water lock exhaust kit 40 mm (1 1/8")
40230291	Water/Gas separator kit 40/40/40 (1 1/8")
40290061	Starter battery - AGM Power 12 VDC 80 Ah (will be charged by Genverter when running)
40290106	Starter battery installation kit incl. Battery Charger - Handy 12 VDC 7 A
40230205	Universal fuel kit
40201304	Box cooler kit GV2/3 - GV8/10 keel cooling, dry exhaust
40201325	Dry exhaust kit 1" keel cooling, dry exhaust

*) WhisperTouch Screen 7" Full color is optional and recommended.

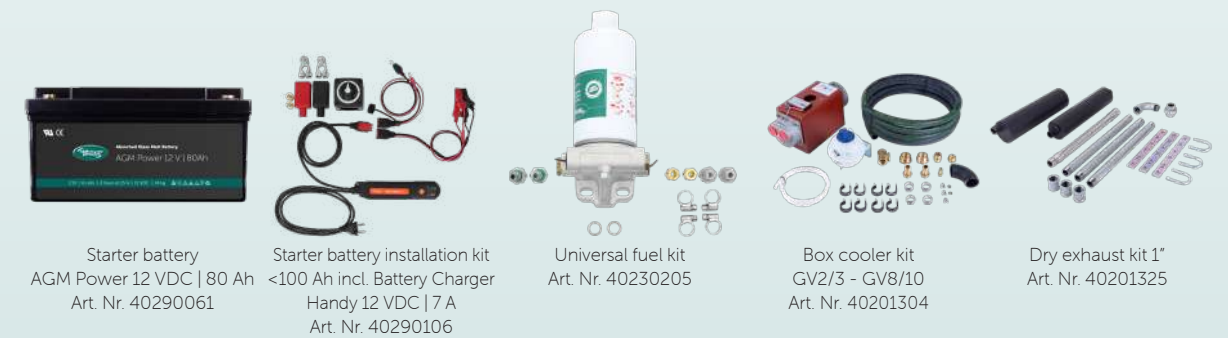

Starter battery AGM Power 12 VDC | 80 Ah Art. Nr. 40290061 | Starter battery installation kit <100 Ah incl. Battery Charger Handy 12 VDC | 7 A Art. Nr. 40290106 | Universal fuel kit Art. Nr. 40230205 | Box cooler kit GV2/3 - GV8/10 Art. Nr. 40201304 | Dry exhaust kit 1" Art. Nr. 40201325

EXTRA ACCESSORIES FOR PICCOLO 6

Article number	Definition
40222244	WPL-15W40 General, Lubricant oil, 4 liters 1 container required
40222214	WPL-Coolant G12+, 4 liters 1 container required
40401770	A-kit maintenance parts
40401771	B-kit maintenance parts



WPL-15W40 General, Lubricant oil, 4 liters Art. Nr. 40222244 | WPL-Coolant G12+ 4 liters Art. Nr. 40222214 | A-kit maintenance parts Art. Nr. 40401770 | B-kit maintenance parts Art. Nr. 40401771



Genverter Piccolo 8



Available variations:

230 VAC | 8 kVA | 6.4 kW | 50 Hz
120 VAC | 6 kVA | 6 kW | 60 Hz

Dimensions Piccolo 8

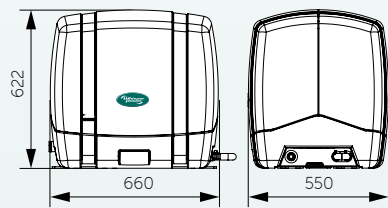

PMG included



DDC remote control panel



6 kVA/8 kVA

PICCOLO 8

Genverter based on Kubota Z482

	230 VAC	120 VAC
System output	8 kVA / 6.4 kW	6 kVA / 6 kW
Peak power 200msec	200%	
RPM range	2400 .. 2800 rpm	
Low rpm setpoint	1800 rpm	
Max rpm setpoint	3200 rpm	
Typical rpm	2400 .. 2600 rpm	
Sound level @ 7m	51 dBA	
Sound level @ 1m	60 dBA	
Cooling	Intercooling	
Exhaust	Wet type, 40 mm (except ..030)	
Speed governor	Mechanical	
Starter battery capacity	12 VDC / 80 Ah	
Standard supplies	fuel filter, fuel lift pump, user and installation manuals (models featuring DDC: digital remote panel, 10 m cable)	

Available options installation kits, non-earth return (ungrounded), spare partskit, longer or shorter DDC cables

MECHANICAL SPECIFICATIONS

Dimensions (l x w x h)	660 x 550 x 662 mm
Dry weight incl. sound shield	155 kg [keel-cooled: 147 kg]
PMG dimensions (h x w x d)	420 x 196 x 148 mm
PMG weight	7.6 kg (230 VAC) 9.9 kg (120 VAC)
Color	RAL9010 signal white, RAL9020 metallic black

ENGINE

Engine model	Kubota Z482
Emission Regulation	Tier 4, EPA
Engine performance intermittent SAE J1349	9.32 kW @ 3600 rpm
Engine performance continuous SAE J1349	8.05 kW @ 3600 rpm
Number of cylinders	2
Displacement	0.479 l
Bore & stroke	67 x 68 mm
Air intake system	Naturally aspirated
Air consumption	< 0.63 m³/min
Fuel oil	Diesel fuel oil (ASTM No. 2-D)
Fuel consumption @ full load	275 g/kWh
Engine cooling	Indirect water cooled (keel-cooling closed)
Alternator	12.5 A
Operating principle	Energize to run
Starter power requirement	0.8 kW
Nominal operation voltage	12 VDC
Monitoring and control	Digital Diesel Control
Protections	Oil temperature and pressure, exhaust/coolant temperature [dry/wet exhaust]
Local control	Start/stop & maintenance
Service interval oil change	200 h
Lubricant	At least CF
Oil capacity	Approx. 3.2 l



ACCESSORIES & OPTIONS FOR PICCOLO 8		
Article number	Definition	
40280101	WhisperTouch 7* (system panel) connection cable included *)	
40230211	Water inlet kit 20 mm (3/4")	
40230273	Syphon breaker kit 20 mm (3/4")	
40230281	Water lock exhaust kit 40 mm (1 5/8")	
40230291	Water/Gas separator kit 40/40/40 (1 5/8")	
40290061	Starter battery - AGM Power 12 VDC 80 Ah (will be charged by Genverter when running)	
40290106	Starter battery installation kit incl. Battery Charger - Handy 12 VDC 7 A	
40230205	Universal fuel kit	
40201304	Box cooler kit GV2/3 - GV8/10	only for keel cooling, dry exhaust
40201325	Dry exhaust kit 1"	only for keel cooling, dry exhaust

) WhisperTouch 7 Full color is optional and recommended



EXTRA ACCESSORIES FOR PICCOLO 8	
Article number	Definition
40222244	WPL-15W40 General, Lubricant oil, 4 liters 1 container required
40222214	WPL-Coolant G12+, 4 liters 1 container required
40401770	A-kit maintenance parts
40401771	B-kit maintenance parts





Genverter Piccolo 10



Available variations:

230 VAC | 10 kVA | 8.5 kW | 50 Hz
120 VAC | 10 kVA | 8.5 kW | 60 Hz

Dimensions Piccolo 10

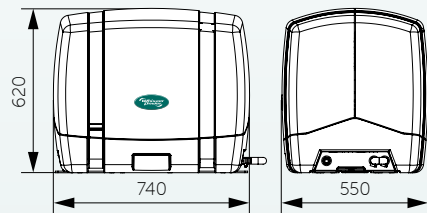

PMG included



DDC remote control panel



10 kVA

PICCOLO 10	
Genverter based on Kubota D722	
230 VAC	120 VAC
System output	10 kVA / 8.5 kW
Peak power 200msec	200%
RPM range	2400 .. 2800 rpm
Low rpm setpoint	2400 rpm
Max rpm setpoint	3200 rpm
Typical rpm	2400 .. 2600 rpm
Sound level @ 7m	51 dBA
Sound level @ 1m	60 dBA
Cooling	Intercooling
Exhaust	Wet type, 40mm (except ..030)
Speed governor	Mechanical
Starter battery capacity	12 VDC / 80 Ah
Standard supplies	fuel filter, fuel lift pump, user and installation manuals (models featuring DDC: digital remote panel, 10 m cable)

Available options	installation kits, non-earth return (ungrounded), spare part kit, longer or shorter DDC cables
-------------------	--

MECHANICAL SPECIFICATIONS

Dimensions (l x w x h)	740 x 550 x 622 mm
Dry weight incl. sound shield	175 kg [keel-cooled: 167 kg]
PMG dimensions (h x w x d) in mm	490 x 198 x 188 542 x 384 x 257
PMG weight	9.9 kg (230 VAC) 20 kg (120 VAC)
Color	RAL9010 signal white, RAL9020 metallic black

ENGINE

Engine model	Kubota D722
Emission Regulation	Tier 4, EPA
Engine performance intermittent SAE J1349	14.0 kW @ 3600 rpm
Engine performance continuous SAE J1349	12.15 kW @ 3600 rpm
Number of cylinders	3
Displacement	0.719 l
Bore & stroke	67 x 68 mm
Air intake system	Naturally aspirated
Air consumption	< 0.94 m ³ /min
Fuel oil	Diesel fuel oil (ASTM No. 2-D)
Fuel consumption @ full load	275 g/kWh
Engine cooling	Indirect water cooled (keel-cooling closed)
Alternator	40 A
Operating principle	Energize to run
Starter power requirement	0.8 kW
Nominal operation voltage	12 VDC
Monitoring and control	Digital Diesel Control
Protections	Oil temperature and pressure, exhaust/coolant temperature [dry/wet exhaust]
Local control	Start/stop & maintenance
Service interval oil change	200 h
Lubricant	At least CF
Oil capacity	Approx. 3.8 l



WhisperTouch 7" Art. Nr. 40280101

Water inlet kit 20 mm (3/4") Art. Nr. 40230211

Syphon breaker kit 20 mm (3/4") Art. Nr. 40230273

Water lock exhaust kit 40 mm (1 1/8") Art. Nr. 40230281

Water/Gas separator kit 40/40/40 (1 1/8") Art. Nr. 40230291

ACCESSORIES & OPTIONS FOR PICCOLO 10

Article number	Definition	
40280101	WhisperTouch 7" (system panel) connection cable included *)	
40230211	Water inlet kit 20 mm (3/4")	
40230273	Syphon breaker kit 20 mm (3/4")	
40230281	Water lock exhaust kit 40 mm (1 1/8")	
40230291	Water/Gas separator kit 40/40/40 (1 1/8")	
40290031	Starter battery - AGM Power 12 VDC 100 Ah (will be charged by Genverter when running)	
40290108	Starter battery installation kit incl. Battery Charger - Handy 12 VDC 7 A	
40230205	Universal fuel kit	
40201304	Box cooler kit GV2/3 - GV8/10	keel cooling, dry exhaust
40201325	Dry exhaust kit 1"	keel cooling, dry exhaust

*) WhisperTouch 7" Full color is optional and recommended



Starter battery AGM Power 12 VDC | 100 Ah Art. Nr. 40290031

Starter battery installation kit >100 Ah incl. Battery Charger Handy 12 VDC | 7 A Art. Nr. 40290108

Universal fuel kit Art. Nr. 40230205

Box cooler kit GV2/3 - GV8/10 Art. Nr. 40201304

Dry exhaust kit 1" Art. Nr. 40201325

EXTRA ACCESSORIES FOR PICCOLO 10

Article number	Definition	
40222244	WPL-15W40 General, Lubricant oil, 4 liters	1 container required
40222214	WPL-Coolant G12+, 4 liters	1 container required
40401770	A-kit maintenance parts	
40401772	B-kit maintenance parts	



WPL-15W40 General, Lubricant oil, 4 liters Art. Nr. 40222244

WPL-Coolant G12+ 4 liters Art. Nr. 40222214

A-kit maintenance parts Art. Nr. 40401770

B-kit maintenance parts Art. Nr. 40401772



Genverter Piccolo 12



Available variations:

230 VAC | 10 kVA | 9.6 kW | 50 Hz
120 VAC | 10 kVA | 9.6 kW | 60 Hz

Dimensions Piccolo 12

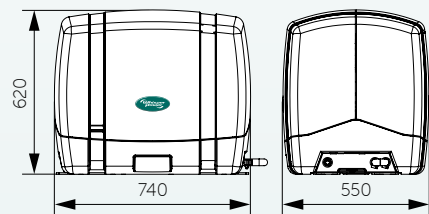

PMG included



DDC remote control panel



10 kVA

PICCOLO 12	
Genverter based on Kubota D722	
System output	10 kVA/9.6 kW
Peak power 200msec	200%
RPM range	2800.. 3300 rpm
Low rpm setpoint	2400 rpm
Max rpm setpoint	3600 rpm
Typical rpm	2400 .. 2600
Sound level @ 7m	54 dBA
Sound level @ 1m	65 dBA
Cooling	Intercooling
Exhaust	Wet type, 40mm (except ..030)
Speed governor	Mechanical
Starter battery capacity	12 VDC / 80 Ah
Standard supplies	fuel filter, fuel lift pump, user and installation manuals (models featuring DDC: digital remote panel, 10 m cable)

Available options installation kits, non-earth return (ungrounded), spare part kit, longer or shorter DDC cables

MECHANICAL SPECIFICATIONS

Dimensions (l x w x h)	740 x 550 x 622 mm
Dry weight incl. sound shield	175 kg [keel-cooled: 167 kg]
PMG dimensions (h x w x d)	490 x 198 x 188 mm
PMG weight	9.9 kg
Color	RAL9010 signal white, RAL9020 metallic black

ENGINE

Engine model	Kubota D722
Emission Regulation	Tier 4, EPA
Engine performance intermittent SAE J1349	14.0 kW @ 3600 rpm
Engine performance continuous SAE J1349	12.15 kW @ 3600 rpm
Number of cylinders	3
Displacement	0.719 l
Bore & stroke	67 x 68 mm
Air intake system	Naturally aspirated
Air consumption	< 1.22 m ³ /min
Fuel oil	Diesel fuel oil (ASTM No. 2-D)
Fuel consumption @ full load	275 g/kWh
Engine cooling	Indirect water cooled (keel-cooling closed)
Alternator	40 A
Operating principle	Energize to run
Starter power requirement	0.8 kW
Nominal operation voltage	12 VDC
Monitoring and control	Digital Diesel Control
Protections	Oil temperature and pressure, exhaust/coolant temperature [dry/wet exhaust]
Local control	Start/stop & maintenance
Service interval oil change	200 h
Lubricant	At least CF
Oil capacity	Approx. 4.0 l



WhisperTouch 7" Art. Nr. 40280101

Water inlet kit 20 mm (3/4") Art. Nr. 40230211

Syphon breaker kit 20 mm (3/4") Art. Nr. 40230273

Water lock exhaust kit 40 mm (1 5/8") Art. Nr. 40230281

Water/Gas separator kit 40/40/40 (1 5/8") Art. Nr. 40230291

ACCESSORIES & OPTIONS FOR PICCOLO 12

Article number	Definition	
40280101	WhisperTouch 7" (system panel) connection cable included *)	
40230211	Water inlet kit 20 mm (3/4")	
40230273	Syphon breaker kit 20 mm (3/4")	
40230281	Water lock exhaust kit 40 mm (1 5/8")	
40230291	Water/Gas separator kit 40/40/40 (1 5/8")	
40290031	Starter battery - AGM Power 12 VDC 100 Ah (will be charged by Genverter when running)	
40290108	Starter battery installation kit incl. Battery Charger - Handy 12 VDC 7 A	
40230205	Universal fuel kit	
40201304	Box cooler kit GV2/3 - GV8/10	keel cooling, dry exhaust
40201325	Dry exhaust kit 1"	keel cooling, dry exhaust

*) WhisperTouch 7" Full color is optional and recommended



Starter battery AGM Power 12 VDC | 100 Ah Art. Nr. 40290031

Starter battery installation kit >100 Ah incl. Battery Charger Handy 12 VDC | 7 A Art. Nr. 40290108

Universal fuel kit Art. Nr. 40230205

Box cooler kit GV2/3 - GV8/10 Art. Nr. 40201304

Dry exhaust kit 1" Art. Nr. 40201325

EXTRA ACCESSORIES FOR PICCOLO 12

Article number	Definition	
40222244	WPL-15W40 General, Lubricant oil, 4 liters	1 container required
40222214	WPL-Coolant G12+, 4 liters	1 container required
40401770	A-kit maintenance parts	
40401772	B-kit maintenance parts	



WPL-15W40 General, Lubricant oil, 4 liters Art. Nr. 40222244

WPL-Coolant G12+ 4 liters Art. Nr. 40222214

A-kit maintenance parts Art. Nr. 40401770

B-kit maintenance parts Art. Nr. 40401772



Genverter Piccolo 15



Available variations:

230 VAC | 15 kVA | 12.5 kW | 50 Hz
120 VAC | 15 kVA | 12.5 kW | 60 Hz

Dimensions Piccolo 15

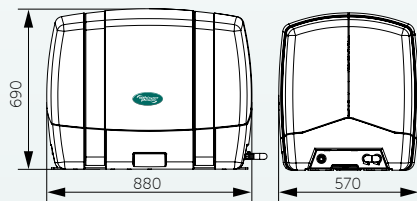

PMG included



DDC remote control panel



15 kVA

PICCOLO 15

Genverter based on Kubota D1105

	230 VAC	120 VAC
System output	15 kVA / 12 kW	15kVA / 12.5 kW
Peak power 200m sec	200%	
RPM range	2000 .. 2600 rpm	
Low rpm set point	1500 rpm	
Max rpm set point	3000 rpm	
Typical rpm	2000 .. 2600 rpm	
Sound level @ 7m	58 dBA	
Sound level @ 1m	74 dBA	
Cooling	Indirect liquid cooling	
Exhaust	Wet type, 40mm (except .030)	
Speed governor	Mechanical	
Starter battery capacity	12 VDC / 90 Ah	
Standard supplies	fuel filter, fuel lift pump, user and installation manuals (models featuring DDC: digital remote panel, 10 m cable)	

Available options installation kits, non-earth return (ungrounded), spare part kit, longer or shorter DDC cables

MECHANICAL SPECIFICATIONS

Dimensions (l x w x h)	882 x 570 x 690 mm
Dry weight incl. sound shield	187 kg [keel-cooled: 200 kg]
PMG dimensions (h x w x d)	542 x 384 x 257 mm
PMG weight	20 kg
Color	RAL9010 signal white, RAL9020 metallic black

ENGINE

Engine model	Kubota D1105
Emission Regulation	Tier 4, EPA & Stage V
Engine performance intermittent SAE J1349	18.7 kW @ 3000 rpm
Engine performance continuous SAE J1349	16.4 kW @ 3000 rpm
Number of cylinders	3
Displacement	1.123 l
Bore & stroke	78 x 78.4 mm
Air intake system	Naturally aspirated
Air consumption	1.47 m ³ /min
Fuel oil	Diesel fuel oil (ASTM No. 2-D, EN590)
Fuel consumption @ full load	275 g/kWh
Engine cooling	Indirect water cooled (keel-cooling closed)
Alternator	40 A
Operating principle	Energize to run
Starter power requirement	1.0 kW
Nominal operation voltage	12 VDC
Monitoring and control	Digital Diesel Control
Protections	Oil temperature and pressure, exhaust/coolant temperature [dry/wet exhaust]
Local control	Start/stop & maintenance
Service interval oil change	200 h
Lubricant	At least CF
Oil capacity	Approx. 4.0 l



WhisperTouch 7" Art. Nr. 40280101

Water inlet kit 20 mm (3/4") Art. Nr. 40230211

Syphon breaker kit 20 mm (3/4") Art. Nr. 40230273

Water lock exhaust kit 40 mm (1 5/8") Art. Nr. 40230281

Water/Gas separator kit 40/40/40 (1 5/8") Art. Nr. 40230291

ACCESSORIES & OPTIONS FOR PICCOLO 15

Article number	Definition
40280101	WhisperTouch 7" (system panel) connection cable included *)
40230211	Water inlet kit 20 mm (3/4")
40230273	Syphon breaker kit 20 mm (3/4")
40230281	Water lock exhaust kit 40 mm (1 5/8")
40230291	Water/Gas separator kit 40/40/40 (1 5/8")
40290031	Starter battery - AGM Power 12 VDC 100 Ah (will be charged by Genverter when running)
40290108	Starter battery installation kit incl. Battery Charger - Handy 12 VDC 7 A
40230205	Universal fuel kit
40201304	Box cooler kit GV2/3 - GV8/10 keel cooling, dry exhaust
40201875	Dry exhaust kit 1 1/2" keel cooling, dry exhaust

*) WhisperTouch 7" is optional and recommended



Starter battery AGM Power 12 VDC | 100 Ah Art. Nr. 40290031

Starter battery installation kit >100 Ah incl. Battery Charger Handy 12 VDC | 7 A Art. Nr. 40290108

Universal fuel kit Art. Nr. 40230205

Box cooler kit GV2/3 - GV8/10 Art. Nr. 40201304

Dry exhaust kit 1 1/2" Art. Nr. 40201875

EXTRA ACCESSORIES FOR PICCOLO 15

Article number	Definition
40222244	WPL-15W40 General, Lubricant oil, 4 liters 2 containers are required
40222214	WPL-Coolant G12+, 4 liters 2 containers are required
40401863	A-kit maintenance parts
40401864	B-kit maintenance parts



WPL-15W40 General, Lubricant oil, 4 liters Art. Nr. 40222244

WPL-Coolant G12+ 4 liters Art. Nr. 40222214

A-kit maintenance parts Art. Nr. 40401863

B-kit maintenance parts Art. Nr. 40401864



Genverter Piccolo 18



Available variations:

230 VAC | 18 kVA | 15 kW | 50 Hz
120 VAC | 18 kVA | 15 kW | 60 Hz

Dimensions Piccolo 15

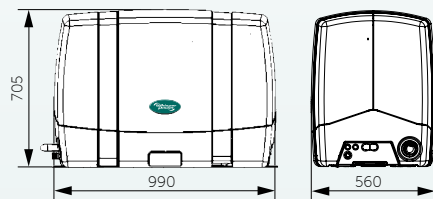

PMG included



DDC remote control panel



18 kVA

PICCOLO 18

Genverter based on
Kubota V1505

System output	18 kVA / 15 kW
Peak power 200m sec	200%
RPM range	2000 .. 2600 rpm
Low rpm set point	1500 rpm
Max rpm set point	3000 rpm
Typical rpm	2000 .. 2400 rpm
Sound level @ 7m	57 dBA
Sound level @ 1m	73 dBA
Cooling	Indirect liquid cooling
Exhaust	Wet type, 40mm (except .030)
Speed governor	Mechanical
Starter battery capacity	12 VDC / 90 Ah
Standard supplies	fuel filter, fuel lift pump, user and installation manuals (models featuring DDC: digital remote panel, 10 m cable)

Available options installation kits, non-earth return (ungrounded), spare part kit, longer or shorter DDC cables

MECHANICAL SPECIFICATIONS

Dimensions (l x w x h)	990 x 560 x 705 mm
Dry weight incl. sound shield	230 kg [keel-cooled: 265 kg]
PMG dimensions (h x w x d)	568 x 347 x 198mm
PMG weight	20 kg
Color	RAL9010 signal white, RAL9020 metallic black

ENGINE

Engine model	Kubota V1505
Emission Regulation	Tier 4, EPA & Stage V
Engine performance intermittent SAE J1349	18.5 kW @ 2300 rpm
Engine performance continuous SAE J1349	16.5 kW @ 2300 rpm
Number of cylinders	4
Displacement	1.489 l
Bore & stroke	78 x 78.4 mm
Air intake system	Naturally aspirated
Air consumption	2.45 m ³ /min
Fuel oil	Diesel fuel oil (ASTM No. 2-D, EN590)
Fuel consumption @ full load	275 g/kWh
Engine cooling	Indirect water cooled (keel-cooling closed)
Alternator	40 A
Operating principle	Energize to run
Starter power requirement	1.0 kW
Nominal operation voltage	12 VDC
Monitoring and control	Digital Diesel Control
Protections	Oil temperature and pressure, exhaust/coolant temperature [dry/wet exhaust]
Local control	Start/stop & maintenance
Service interval oil change	200 h
Lubricant	At least CF
Oil capacity	Approx. 4.0 l



WhisperTouch 7"
Art. Nr. 40280101

Water inlet kit
20 mm (3/4")
Art. Nr. 40230211

Syphon breaker kit
20 mm (3/4")
Art. Nr. 40230273

Water lock exhaust kit
40 mm (1 5/8")
Art. Nr. 40230281

Water/Gas separator kit
40/40/40 (1 5/8")
Art. Nr. 40230291

ACCESSORIES & OPTIONS FOR PICCOLO 18

Article number	Definition
40280101	WhisperTouch 7" (system panel) connection cable included *)
40230211	Water inlet kit 20 mm (3/4")
40230273	Syphon breaker kit 20 mm (3/4")
40230281	Water lock exhaust kit 40 mm (1 5/8")
40230291	Water/Gas separator kit 40/40/40 (1 5/8")
40290031	Starter battery - AGM Power 12 VDC 100 Ah (will be charged by Genverter when running)
40290108	Starter battery installation kit incl. Battery Charger - Handy 12 VDC 7 A
40230205	Universal fuel kit
40201304	Box cooler kit GV2/3 - GV8/10 keel cooling, dry exhaust
40201875	Dry exhaust kit 1 1/2" keel cooling, dry exhaust

*) WhisperTouch 7" is optional and recommended.

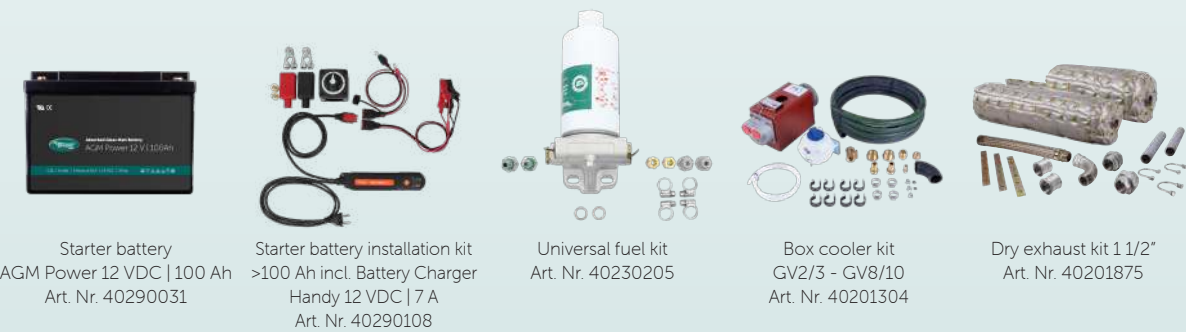

Starter battery
AGM Power 12 VDC | 100 Ah
Art. Nr. 40290031

Starter battery installation kit
>100 Ah incl. Battery Charger
Handy 12 VDC | 7 A
Art. Nr. 40290108

Universal fuel kit
Art. Nr. 40230205

Box cooler kit
GV2/3 - GV8/10
Art. Nr. 40201304

Dry exhaust kit 1 1/2"
Art. Nr. 40201875

EXTRA ACCESSORIES FOR PICCOLO 18

Article number	Definition
40222244	WPL-15W40 General, Lubricant oil, 4 liters 2 containers are required
40222214	WPL-Coolant G12+, 4 liters 2 containers are required
40401863	A-kit maintenance parts
40401864	B-kit maintenance parts



WPL-15W40
General, Lubricant oil, 4 liters
Art. Nr. 40222244

WPL-Coolant G12+
4 liters
Art. Nr. 40222214

A-kit maintenance parts
Art. Nr. 40401863

B-kit maintenance parts
Art. Nr. 40401864



Piccolo Genverter®

Double the power, reduce fuel and maintenance costs

A complete range of compact, adjustable speed single phase AC diesel generators based on inverter technology, our new Twin-Power range. The upgraded Genverter range can now be delivered with parallel connectivity which is adding just a fraction to the price but offering huge advantages.



1+1=3
more benefits than just two Generators

Important system benefits

Traditional fixed speed generators are chosen in general in oversize, based on the peak load power requirements. This often means they are oversized for their normal operation running load. With the Twin-Power solution, the AC appliances are powered by one or two engines. As a result of our Genverter variable speed inverter technology, the engines are running in their most fuel efficient operation area which results in the following benefits:

1. Double the power, if needed, for example day time (high A/C consumption)
2. Reduce the power during the night, switch back to one running engine
3. Optimized voltage & frequency stabilization ensures excellent power quality
4. Optimized noise level and vibration level is guaranteed
5. Engines are running cleaner with less fuel consumption
6. Compact Genverter technology offering substantial space saving
7. New emission level Stage V compliant also in higher kVA range (30 kVA/24 kW)
8. Redundancy, always one power source for spare

Cost saving and redundant

This Twin-Power concept is offering at least 25% of fuel saving compared with traditional 1500/1800 RPM generators, as the units will follow the required AC power consumption pattern (low mode, high mode).

Traditional power generator systems are in general oversized in order to be able to deliver the peak of power consumption which on average general has a short duration. By installing two Genverter generators in parallel, one unit can be switched off during low power consumption periods. Very important advantage of the power solution is the redundancy of power sources offered by this solution.

Twin system example

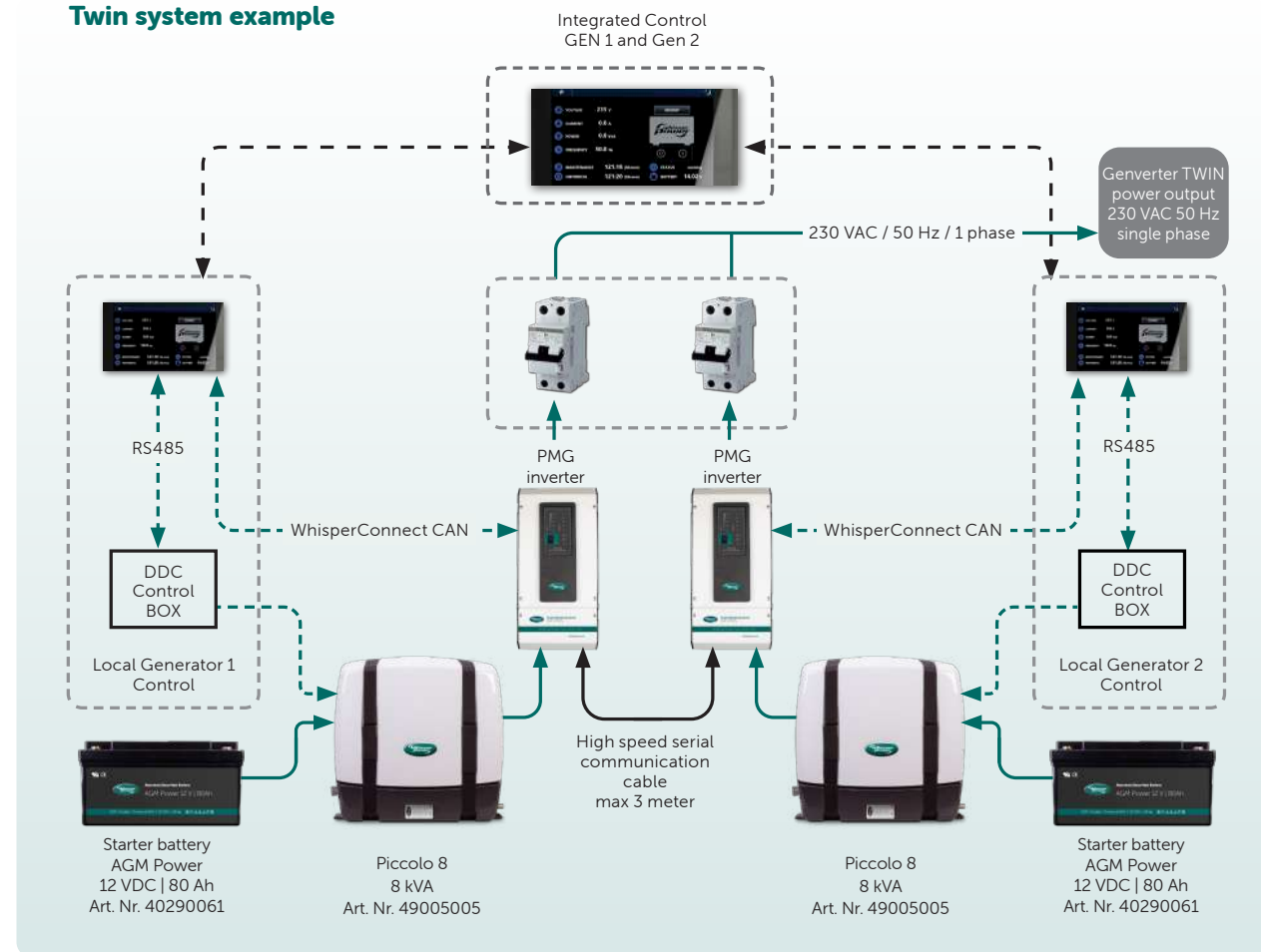

Easy to install & configure

Our Twin-Power® solution allows you to parallel two WhisperPower Genverter generators with a single high speed communication wire. No extra boxes with oversized switch gear are needed, or other costly add-ons. Just install two generators instead of one traditional product and connect the PMG inverters plus the AC outputs to double the AC Power.

Some more about running generators in parallel

As said, paralleling our Genverter generators can be done simply by connecting two Genverters of the same size together to provide two times the nominal power but also two times the peak power.

There are several reasons why boat owners should not "just buy a larger generator."

The most common problem of oversized generators is the negative effect on the diesel engine which starts to pollute, smoke, delivers soot and in the end will show glazing effect of the cylinders. Apart from the fact our Genverter generators are more fuel efficient and significantly quieter than a comparable sized 1500/1800 rpm generator, they run at the right RPM at any time and can operate even in eco mode.



Piccolo Twin Twin Range



	PICCOLO TWIN 8+8		PICCOLO TWIN 10+10		PICCOLO TWIN 12+12		PICCOLO TWIN 15+15		PICCOLO TWIN 18+18	
	49005080		49009080		49006080		49007080		49008080	
MAIN SPECIFICATIONS	Single mode	Twin mode	Single mode	Twin mode	Single mode	Twin mode	Single mode	Twin mode	Single mode	Twin mode
Intermittent Power kW at 25°C (77°F)	6.4 kW	12.8 kW	8.5 kW	17 kW	9.6 kW	19.2 kW	12.5 kW	25 kW	15 kW	30 kW
Continuous Power kVA at 25°C (77°F)	8 kVA	16 kVA	10 kVA	20 kVA	10 kVA	20 kVA	15 kVA	30 kVA	18 kVA	36 kVA
Continuous Power kW at 25°C (77°F)	6 kW	12 kW	8 kW	16 kW	9 kW	18 kW	12 kW	24 kW	15 kW	30 kW
Noise level	51 dB(A) at 7 m, 60 dB(A) at 1 m		51 dB(A) at 7 m, 60 dB(A) at 1 m		54 dB(A) at 7 m, 65 dB(A) at 1 m		54 dB(A) at 7 m, 65 dB(A) at 1 m		57 dB(A) at 7 m, 73 dB(A) at 1 m	
RPM range	2400 .. 2800 rpm, adjustable		2400 .. 2800 rpm, adjustable		2200 .. 3600 rpm, adjustable		2200 .. 3600 rpm, adjustable		2000 .. 2400 rpm adjustable	
Alternator technology	Permanent Magnet		Permanent Magnet		Permanent Magnet		Permanent Magnet		Permanent Magnet	
Generator cooling	Liquid cooled		Liquid cooled		Liquid cooled		Liquid cooled		Air cooled	
Generator control	DDC (2x)		DDC (2x)		DDC (2x)		DDC (2x)		DDC (2x)	
Control Panel	DDC Local + DDC Remote		DDC Local + DDC Remote		DDC Local + DDC Remote		DDC Local + DDC Remote		DDC Local + DDC Remote	
Inverter Module	WP-PMG frame 2 (2x)		WP-PMG frame 2 (2x)		WP-PMG frame 2 (2x)		WP-PMG frame 3 (2x)		WP-PMG frame 2 (2x)	
Twin Power Communication Cable	Max. 3 meters		Max. 3 meters		Max. 3 meters		Max. 3 meters		Max. 3 meters	
Nominal voltage / frequency	230 VAC - 50/60 Hz		230 VAC - 50/60 Hz		230 VAC - 50/60 Hz		230 VAC - 50/60 Hz		230 VAC - 50/60 Hz	
Phase/wire	1 phase 3 wire		1 phase 3 wire		1 phase 3 wire		1 phase 3 wire		1 phase 3 wire	
Peak power 2 s	200%		200%		200%		200%		200%	
Harmonic distortion	< 3%		< 3%		< 3%		< 3%		< 5%	
Frequency tolerance	± 0.1%		± 0.1%		± 0.1%		± 0.1%		± 0.1%	
DIESEL ENGINE SPECIFICATIONS	WhisperPower Kubota Z482		WhisperPower Kubota D722		WhisperPower Kubota D1105		WhisperPower Kubota D1105		WhisperPower Kubota V1505	
Displacement	479 cc		719 cc		1.123 cc		1.123 cc		1.489 cc	
Cylinders	2		3		3		3		4	
Bore & stroke	67 x 68 mm		67 x 68 mm		78 x 78.4 mm		78 x 78.4 mm		78 x 78.4 mm	
Compression ratio	23.5		23.5		24.0		24.0		24.0	
Air consumption	< 0.63 m ³ /min (per unit)		< 0.94 m ³ /min (per unit)		< 1.47 m ³ /min (per unit)		< 1.47 m ³ /min (per unit)		< 1.47 m ³ /min (per unit)	
Cooling system	Heat exchanger		Heat exchanger		Heat exchanger		Heat exchanger		Heat exchanger	
Fuel consumption (no load - full load)	1.7-2.5 l/hr (per unit)		2.6-3.8 l/hr (per unit)		4.2-5.6 l/hr (per unit)		4.2-5.6 l/hr (per unit)		4.2-5.6 l/hr (per unit)	
Starter battery charge method/ current	Alternator 12 V/12.5 A		Alternator 12 V/12.5 A		Alternator 12 V/12.5 A		Alternator 12 V/12.5 A		Alternator 12 V/40 A	
DIMENSIONS & WEIGHT	660 x 550 x 622 mm /each		740 x 550 x 622 mm /each		882 x 570 x 690 mm /each		882 x 570 x 690 mm /each		990 x 560 x 705 mm /each	
Length x width x depth (PMG)	490 x 198 x 188 mm /each		490 x 198 x 188 mm /each		490 x 198 x 188 mm /each		542 x 384 x 257 mm /each		568 x 347 x 198 mm /each	
Dry weight (cabinet + PMG)	155 kg + 9.9 kg /each		175 kg + 9.9 kg /each		210 kg + 20 kg /each		210 kg + 20 kg /each		230 kg + 20 kg /each	
Exhaust type	Ø 40 mm, wet		Ø 40 mm, wet		Ø 40 mm, wet		Ø 40 mm, wet		Ø 40 mm, wet	
Max. operating angle	25° in all directions		25° in all directions		25° in all directions		25° in all directions		25° in all directions	
OPTIONAL	2 nd start/stop panel, Touch panel 7" (2x)		2 nd start/stop panel, Touch panel 7" (2x)		2 nd start/stop panel, Touch panel 7" (2x)		2 nd start/stop panel, Touch panel 7" (2x)		Touch panel, PEK (Piccolo extension kit)	
	Ungrounded		Ungrounded		Ungrounded		Ungrounded		Ungrounded	
	Keel Cooling		Keel Cooling		Keel Cooling		Keel Cooling		Keel Cooling	





Summary of all Piccolo Genverter models

Piccolo 230/120 VAC



Piccolo 4
1 cylinder
3.5 kVA / 3.5 kW



Piccolo 5
1 cylinder
4.4 kVA / 3.5 kW



Piccolo 6
2 cylinder
6 kVA / 6 kW



Piccolo 8
2 cylinder
8 kVA / 6.4 kW



Piccolo 10
3 cylinder
10 kVA / 8 kW



Piccolo 12
3 cylinder
10 kVA / 9.6 kW



Piccolo 15
3 cylinder
15 kVA / 12.5 kW



Piccolo 18
4 cylinder
18 kVA / 15 kW

Important information about Ungrounded units:

All our Ungrounded generator systems are, during the start-stop procedure, connected to ground by a ground-relay

Summary of all Twin models

Piccolo 230/120 VAC



Piccolo 8 + 8
2 cylinder
16 kVA / 12.8 kW



Piccolo 10 + 10
3 cylinder
20 kVA / 17 kW



Piccolo 12 + 12
3 cylinder
20 kVA / 19.2 kW



Piccolo 15 + 15
3 cylinder
30 kVA / 25 kW



Piccolo 18 + 18
4 cylinder
36 kVA / 30 kW

System explained

What a complete generator system looks like

This page provides an overview of all the essential installation equipment for a generator system. We recommend only using original WhisperPower parts. We provide installation kits for all of our generator models to facilitate installation. All products are high quality and specifically designed for the intended function.

Marine

Installation example





Piccolo Genverter® DC generator / inverter system

For cases when a constant high power consumption isn't required, installing a Genverter® system with the DC PowerCube, combined with an AC PowerCube inverter, can prove to be a smart decision. The advantage of this system is that a non-stop AC power supply is always available. This is thanks to the 4, 7 or 14 kVA AC PowerCube inverter which is connected to one or multiple onboard batteries being charged by one or several DC PowerCubes.

Whenever the 24 VDC / 48 VDC batteries need to be recharged, the Genverter® starts up automatically. At the same time, the DC PowerCube is connected to the shore power - during shore power connection, the various onboard batteries are charged with a

maximum of 120 A (3.5 kW). Using the remote control panel, supplied as standard, the shore power can be set to the required ampere value (4,6,8,10,16 A). The DC PowerCube also features a charging socket for 24 VDC batteries (or 48 VDC).

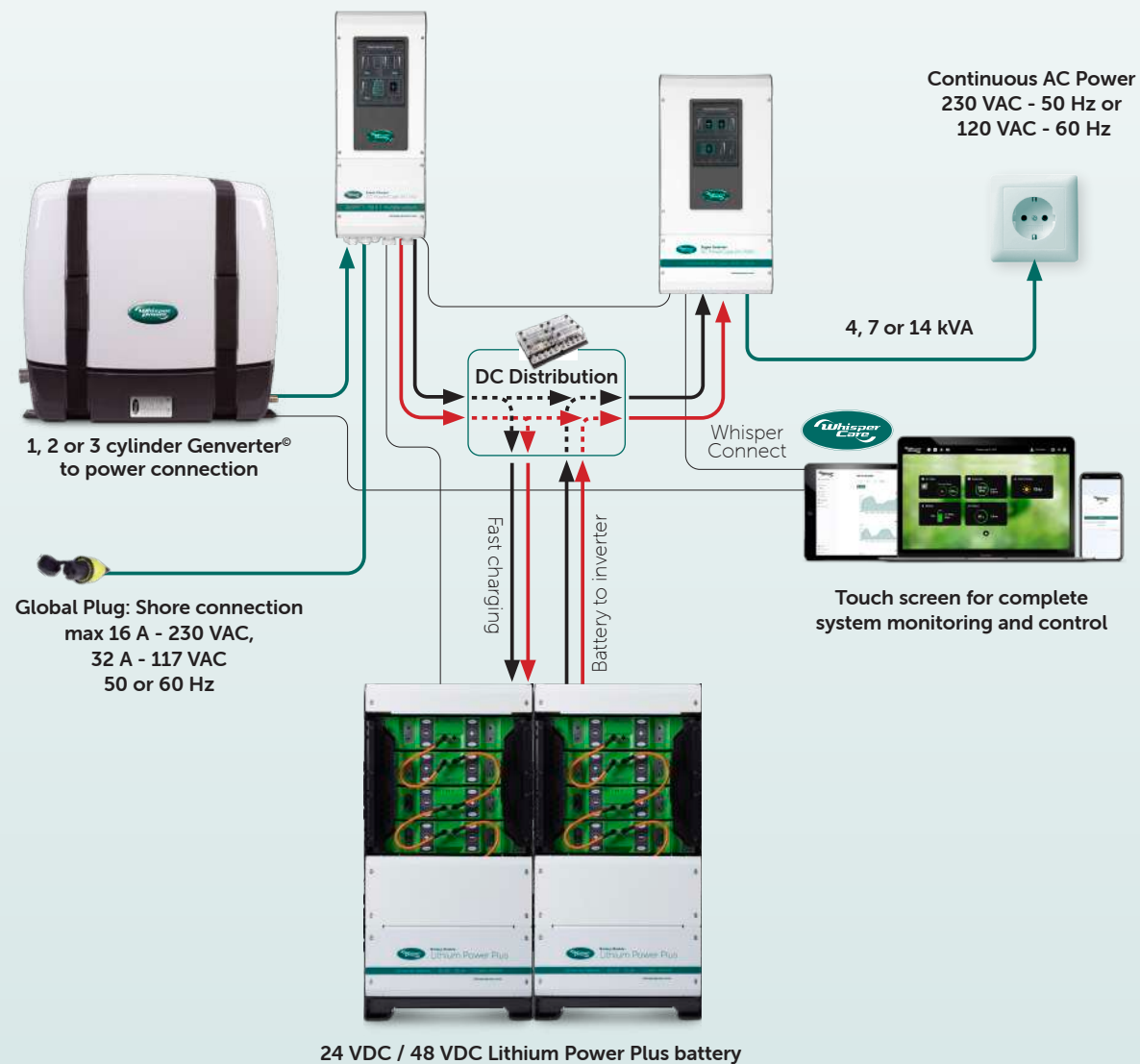

ADJUSTABLE
SPEED
DC
OUTPUT



PICCOLO 2	PICCOLO 3	PICCOLO 3+
49001105	49001305	49001505
49001106 - Ungrounded	49001306 - Ungrounded	49001506 - Ungrounded
49001130 - Keel cooling	49001330 - Keel Cooling	49001530 - Keel cooling

MAIN SPECIFICATIONS			
Continuous Power at 25°C (77°F)	4.3 kW	8.6 kW	12 kW
Number of DC PowerCubes	1	2	3
Nominal voltage	24/48 VDC	24/48 VDC	24/48 VDC
Charge characteristics	Bulk, absorption, float	Bulk, absorption, float	Bulk, absorption, float
Noise level	51 dB(A) at 7 m, 60 dB(A) at 1 m	51 dB(A) at 7 m, 60 dB(A) at 1 m	54 dB(A) at 7 m, 65 dB(A) at 1 m
RPM range	1500 .. 3000 rpm, adjustable	1500 .. 2500 rpm, adjustable	1500 .. 2500 rpm, adjustable
Alternator technology	Permanent Magnet	Permanent Magnet	Permanent Magnet
Generator cooling	Indirect water-cooling (engine+alternator)	Indirect water-cooling (engine+alternator)	Indirect water-cooling (engine+alternator)
Generator control	DDC	DDC	DDC
Control Panel	DDC Local + DDC Remote	DDC Local + DDC Remote	DDC Local + DDC Remote

DIESEL ENGINE SPECIFICATIONS			
Engine	WP Kubota Z482	WP Kubota D722	WP Kubota D1105
Displacement	479 cc	719 cc	1123 cc
Cylinders	2	3	3
Bore & stroke	67 x 68 mm	67 x 68 mm	87 x 78.4 mm
Compression ratio	23.5	23.5	24.0
Air consumption	< 0.63 m³/min	< 0.94 m³/min	< 1.47 m³/min
Cooling system	Heat exchanger	Heat exchanger	Heat exchanger
Fuel consumption (no load - full load)	1.7-2.5 l/hr	2.6-3.8 l/hr	4.2-5.6 l/hr
Starter battery charge method/ current	Alternator 12 VDC / 12.5 A	Alternator 12 VDC / 12.5 A	Alternator 12 VDC / 40 A

DIMENSIONS & WEIGHT			
Length x width x height (cabinet)	660 x 550 x 622 mm	740 x 550 x 622 mm	875 x 570 x 690 mm
Length x width x depth (DC PowerCube)	575 x 221 x 316 mm	575 x 221 x 316 mm	575 x 221 x 316 mm
Dry weight (cabinet + DC PowerCube)	155 kg + 26 kg	175 kg + 2 x 26 kg	210 kg + 3 x 26 kg
Exhaust type	Ø 40 mm, wet	Ø 40 mm, wet	Ø 40 mm, wet
Max. operating angle	25° in all directions	25° in all directions	25° in all directions

OPTIONAL			
	2 nd start/stop panel, Touch panel 7"	2 nd start/stop panel, Touch panel 7"	2 nd start/stop panel, Touch panel 7"
	Ungrounded	Ungrounded	Ungrounded
	Keel Cooling	Keel Cooling	Keel Cooling



Genverter Piccolo 5 - DC use (12 / 24 VDC)



GENVERTER - PROGRAMMABLE SPEED GENERATORS • DC SERIES

Article number	Definition
49003005	Piccolo 5 1 Cyl. 230 VAC / 4.4 kVA / 3.5 kW / 50 Hz • with standard start/stop panel
DC BATTERY CHARGING 24 VDC OR 48 VDC	
60205401	Supreme Pro 24 VDC 100 A (for 12 VDC select one or more Supreme 12 VDC 100 A)

*) DDC Remote start/stop panel and PMG inverter as standard included in the delivery. DC PowerCube is not included.

Dimensions Piccolo 5

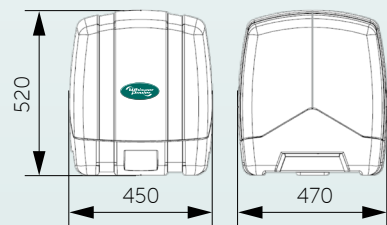

Dimensions Supreme Pro 24 | 100

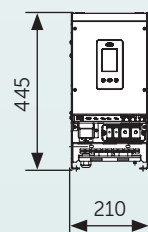

Dimensions Supreme 12 | 100

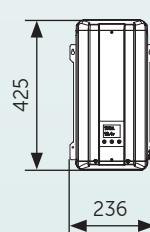

ACCESSORIES & OPTIONS FOR PICCOLO 5

Article number	Definition
40280101	WhisperTouch 7" System Panel *)
40230201	Water inlet kit 12.5 mm (1/2")
40230272	Syphon breaker kit 12.5 mm (1/2")
40230281	Water lock exhaust kit 40 mm (1 5/8")
40230291	Water/Gas separator kit 40/40/40 (1 5/8")
40230208	Base plate kit aluminium (dimensions 600 x 400 x 20)
40290060	Starter battery - AGM Power 12 VDC 55 Ah (will be charged by Genverter when running)
40290106	Starter battery installation kit (recommended for temporary laying) incl. Battery Charger - Handy 12 VDC 7 A
40230205	Universal fuel kit

*) WhisperTouch 7" is optional



EXTRA ACCESSORIES FOR PICCOLO 5

Article number	Definition
40222244	WPL-15W40 General, Lubricant oil, 4 liters 1 container required
40401170	A-kit maintenance parts
40401171	B-kit maintenance parts



Genverter Piccolo GV/2K - DC use



Available variations:

24 VDC | 150 A
48 VDC | 80 A

Dimensions Piccolo GV/2 K

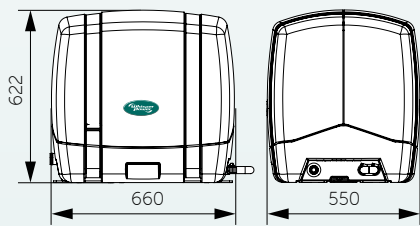

DDC remote control panel



4.3 kW

Continuous Power (24 / 48 VDC)	4.3 kW
Number of DC PowerCubes	1
Nominal voltage / frequency	24/48 VDC
Charge characteristics	bulk, absorption, float
Noise level	51 dB(A) at 7 m, 60 dB(A) at 1 m
RPM range	1500 .. 3000 rpm, adjustable
Generator	Permanent Magnet Alternator (PMA)

DIESEL ENGINE SPECIFICATIONS

Engine	Kubota Z482
Cylinder volume	479 cc (two cylinder)
Bore & stroke	67 x 68 mm
Air consumption	< 0.95 m ³ /min
Cooling system	indirect
Fuel consumption (no load - full load)	1.2-2.5 l/hr
Starter battery charge current	Alternator 12 VDC / 12.5 A

DIMENSIONS & WEIGHT

Length x width x height (cabinet)	660 x 550 x 622 mm
Length x width x depth (DC PowerCube)	575 x 221 x 316 mm
Dry weight (cabinet + DC PowerCube)	155 kg + DC PowerCube
Dry exhaust / wet exhaust	Ø 1 inch BSP / Ø 40 mm
Oil dipstick	Top and side
Max. operating angle	25° in all directions

CONTROL PANEL

Standard	start / stop panel - DDC
Optional	2 nd start/stop panel, Touch panel 7 inch

PICCOLO GV/2K

49001105 GV/2
Kubota, wet exhaust

60202002
DC PowerCube 24/150

60202003
DC PowerCube 48/80

Dimensions DC PowerCube

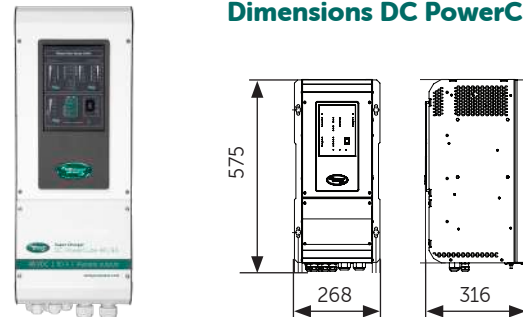

WhisperTouch 7" Art. Nr. 40280101
Water inlet kit 20 mm (3/4") Art. Nr. 40230211
Syphon breaker kit 20 mm (3/4") Art. Nr. 40230273
Water lock exhaust kit 40 mm (1 1/8") Art. Nr. 40230281
Water/Gas separator kit 40/40/40 (1 1/8") Art. Nr. 40230291

ACCESSORIES & OPTIONS FOR PICCOLO GV/2 K

Article number	Definition	
40280101	WhisperTouch 7" (system panel) connection cable included (optional)	
40230211	Water inlet kit 20 mm (3/4")	
40230273	Syphon breaker kit 20 mm (3/4")	
40230281	Water lock exhaust kit 40 mm (1 1/8")	
40230291	Water/Gas separator kit 40/40/40 (1 1/8")	
40290061	Starter battery - AGM Power 12 VDC 80 Ah (will be charged by Genverter when running)	
40290106	Starter battery installation kit incl. Battery Charger - Handy 12 VDC 7 A	
40230205	Universal fuel kit	
40201304	Box cooler kit GV2/3 - GV8/10	keel cooling, dry exhaust
40201325	Dry exhaust kit 1"	keel cooling, dry exhaust

WhisperTouch 7" system panel is optional and recommended.

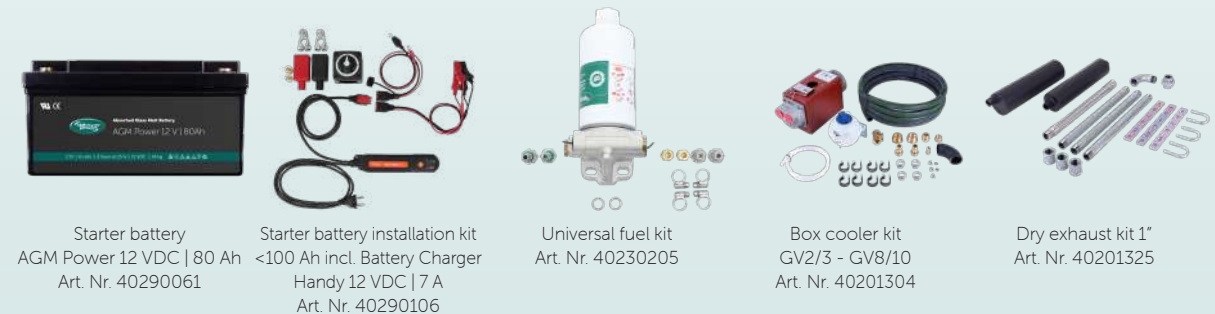

Starter battery AGM Power 12 VDC | 80 Ah Art. Nr. 40290061
Starter battery installation kit <100 Ah incl. Battery Charger Handy 12 VDC | 7 A Art. Nr. 40290106
Universal fuel kit Art. Nr. 40230205
Box cooler kit GV2/3 - GV8/10 Art. Nr. 40201304
Dry exhaust kit 1" Art. Nr. 40201325

EXTRA ACCESSORIES FOR PICCOLO GV/2 K

Article number	Definition	
40222244	WPL-15W40 General, Lubricant oil, 4 liters	1 container required
40222214	WPL-Coolant G12+, 4 liters	1 container required
40401770	A-kit maintenance parts	
40401772	B-kit maintenance parts	



WPL-15W40 General, Lubricant oil, 4 liters Art. Nr. 40222244
WPL-Coolant G12+ 4 liters Art. Nr. 40222214
A-kit maintenance parts Art. Nr. 40401770
B-kit maintenance parts Art. Nr. 40401772





Genverter Piccolo GV/3K - DC use



Available variations:

24 VDC | 300 A
48 VDC | 160 A

Dimensions Piccolo GV/3K

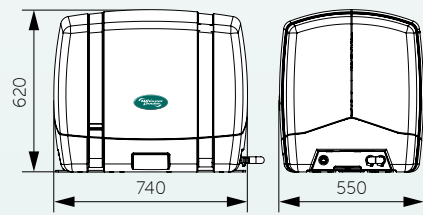

DDC remote control panel



8.6 kW

Continuous Power (24 / 48 VDC)	8.6 kW
Number of DC PowerCubes	2
Nominal voltage / frequency	24/48 VDC
Charge characteristics	bulk, absorption, float
Noise level	51 dB(A) at 7 m, 60 dB(A) at 1 m
RPM range	1500 .. 2500 rpm, adjustable
Generator	Permanent Magnet Alternator (PMA)

DIESEL ENGINE SPECIFICATIONS

Engine	Kubota D722
Cylinder volume	719 cc (three cylinder)
Bore & stroke	67 x 68 mm
Air consumption	< 1.22 m ³ /min
Cooling system	indirect
Fuel consumption (no load - full load)	1.2-3 l/hr
Starter battery charge current	alternator 12 VDC / 12.5 A

DIMENSIONS & WEIGHT

Length x width x height (cabinet)	740 x 550 x 622 mm
Length x width x depth (DC PowerCube)	575 x 221 x 316 mm
Dry weight (cabinet + DC PowerCube)	175 kg + DC PowerCube
Dry exhaust / wet exhaust	Ø 1 inch BSP / Ø 40 mm
Oil dipstick	Top and side
Max. operating angle	25° in all directions

CONTROL PANEL

Standard	start / stop panel - DDC
Optional	2 nd start/stop panel, Touch panel 7 inch

Dimensions DC PowerCube

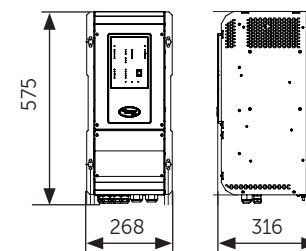

PICCOLO GV/3K

49001305 GV/3
Kubota, wet exhaust

60202002
DC PowerCube 24/150

60202003
DC PowerCube 48/80



WhisperTouch 7" Art. Nr. 40280101

Water inlet kit 20 mm (3/4") Art. Nr. 40230211

Syphon breaker kit 20 mm (3/4") Art. Nr. 40230273

Water lock exhaust kit 40 mm (1 5/8") Art. Nr. 40230281

Water/Gas separator kit 40/40/40 (1 5/8") Art. Nr. 40230291

ACCESSORIES & OPTIONS FOR PICCOLO GV/3 K

Article number	Definition	
40280101	WhisperTouch 7" (system panel) connection cable included (optional)	
40230211	Water inlet kit 20 mm (3/4")	
40230273	Syphon breaker kit 20 mm (3/4")	
40230281	Water lock exhaust kit 40 mm (1 5/8")	
40230291	Water/Gas separator kit 40/40/40 (1 5/8")	
40290061	Starter battery - AGM Power 12 VDC 80 Ah (will be charged by Genverter when running)	
40290106	Starter battery installation kit incl. Battery Charger - Handy 12 VDC 7 A	
40230205	Universal fuel kit	
40201304	Box cooler kit GV2/3 - GV8/10	keel cooling, dry exhaust
40201325	Dry exhaust kit 1"	keel cooling, dry exhaust

WhisperTouch 7" system panel is optional and recommended

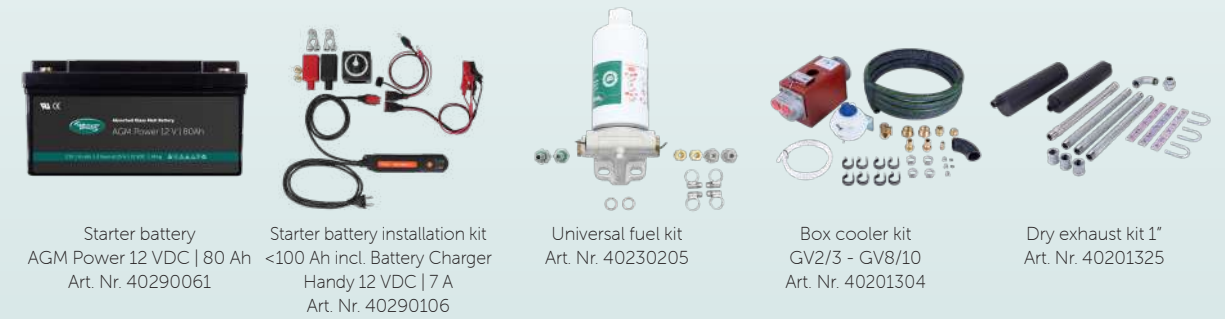

Starter battery AGM Power 12 VDC | 80 Ah Art. Nr. 40290061

Starter battery installation kit <100 Ah incl. Battery Charger Handy 12 VDC | 7 A Art. Nr. 40290106

Universal fuel kit Art. Nr. 40230205

Box cooler kit GV2/3 - GV8/10 Art. Nr. 40201304

Dry exhaust kit 1" Art. Nr. 40201325

EXTRA ACCESSORIES FOR PICCOLO GV/3 K

Article number	Definition	
40222244	WPL-15W40 General, Lubricant oil, 4 liters	1 container required
40222214	WPL-Coolant G12+, 4 liters	1 container required
40401770	A-kit maintenance parts	
40401772	B-kit maintenance parts	



WPL-15W40 General, Lubricant oil, 4 liters Art. Nr. 40222244

WPL-Coolant G12+ 4 liters Art. Nr. 40222214

A-kit maintenance parts Art. Nr. 40401770

B-kit maintenance parts Art. Nr. 40401772



Genverter Piccolo GV/3K Plus - DC use



Available variations:

24 VDC | 450 A
48 VDC | 240 A

Dimensions Piccolo GV/3K Plus

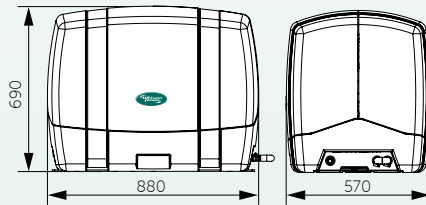

DDC remote control panel



12 kW

Continuous Power (24 / 48 VDC)	12 kW
Number of DC PowerCubes	3
Nominal voltage / frequency	24/48 VDC
Charge characteristics	bulk, absorption, float
Noise level	54 dB(A) at 7 m, 65 dB(A) at 1 m
RPM range	1500 .. 2500 rpm, adjustable
Generator	Permanent Magnet Alternator (PMA)

DIESEL ENGINE SPECIFICATIONS

Engine	Kubota D1105
Cylinder volume	1123 cc (three cylinder)
Bore & stroke	87 x 78.4 mm
Air consumption	< 1.43 m ³ /min
Cooling system	indirect
Fuel consumption (no load - full load)	1.5-4 l/hr
Starter battery charge current	Alternator 12 VDC / 40 A

DIMENSIONS & WEIGHT

Length x width x height (cabinet)	875 x 570 x 690 mm
Length x width x depth (DC PowerCube)	575 x 221 x 316 mm
Dry weight (cabinet + DC PowerCube)	210 kg + DC PowerCube
Dry exhaust / wet exhaust	Ø 1 inch BSP / Ø 40 mm
Oil dipstick	Top and side
Max. operating angle	25° in all directions

CONTROL PANEL

Standard	start / stop panel - DDC
Optional	2 nd start/stop panel, Touch panel 7 inch

Dimensions DC PowerCube

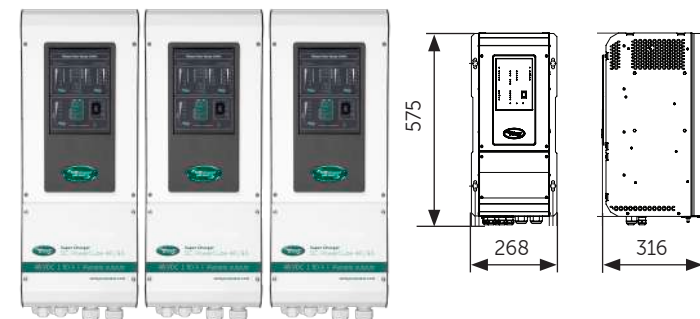

PICCOLO GV/3K PLUS

49001505 GV/3+
Kubota, wet exhaust

60202002
DC PowerCube 24/150

60202003
DC PowerCube 48/80



WhisperTouch 7" Art. Nr. 40280101
Water inlet kit 20 mm (3/4") Art. Nr. 40230211
Syphon breaker kit 20 mm (3/4") Art. Nr. 40230273
Water lock exhaust kit 40 mm (1 5/8") Art. Nr. 40230281
Water/Gas separator kit 40/40/40 (1 5/8") Art. Nr. 40230291

ACCESSORIES & OPTIONS FOR PICCOLO GV/3 K PLUS

Article number	Definition
40280101	WhisperTouch 7" (system panel) connection cable included (optional)
40230211	Water inlet kit 20 mm (3/4")
40230273	Syphon breaker kit 20 mm (3/4")
40230281	Water lock exhaust kit 40 mm (1 5/8")
40230291	Water/Gas separator kit 40/40/40 (1 5/8")
40290031	Starter battery - AGM Power 12 VDC 100 Ah (will be charged by Genverter when running)
40290108	Starter battery installation kit incl. Battery Charger - Handy 12 VDC 7 A
40230205	Universal fuel kit
40201304	Box cooler kit GV2/3 - GV8/10 keel cooling, dry exhaust
40201875	Dry exhaust kit 1 1/2" keel cooling, dry exhaust

WhisperTouch 7" system panel is optional and recommended

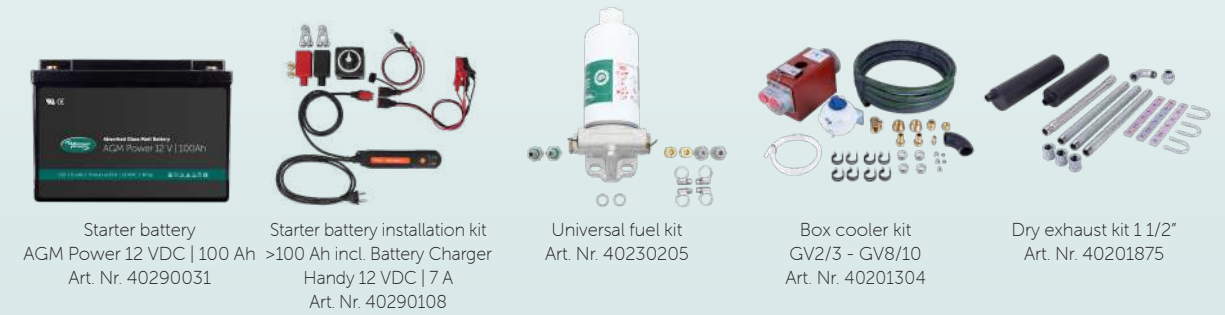

Starter battery AGM Power 12 VDC | 100 Ah Art. Nr. 40290031
Starter battery installation kit >100 Ah incl. Battery Charger Handy 12 VDC | 7 A Art. Nr. 40290108
Universal fuel kit Art. Nr. 40230205
Box cooler kit GV2/3 - GV8/10 Art. Nr. 40201304
Dry exhaust kit 1 1/2" Art. Nr. 40201875

EXTRA ACCESSORIES FOR PICCOLO GV/3 K PLUS

Article number	Definition
40222244	WPL-15W40 General, Lubricant oil, 4 liters 2 containers are required
40222214	WPL-Coolant G12+, 4 liters 2 containers are required
40401863	A-kit maintenance parts
40401864	B-kit maintenance parts



WPL-15W40 General, Lubricant oil, 4 liters Art. Nr. 40222244
WPL-Coolant G12+ 4 liters Art. Nr. 40222214
A-kit maintenance parts Art. Nr. 40401863
B-kit maintenance parts Art. Nr. 40401864

DC Generator system - our Octopower Power solution for 24 / 48 VDC

WhisperPower produces advanced fast charging systems suitable for lithium or lead-acid batteries. Available as a complete DC kit with 24 or 48 VDC batteries, DC distribution system, shorepower/ isolating transformer, and optionally, a robust DC AC inverter of any power rating. Use:

- As a back-up system for electric propulsion, with the certainty of always getting home
- As a silent power source in a system with large DC AC inverter, always power and never power shortage

How it works

The heart of the DC OctoPower system is a battery bank that feeds the DC system and eventually, at the same time, a WhisperPower inverter. This (lithium) battery pack is rechargeable from different sources, including a land power/ dock connection, solar/ wind generator and of course from the Piccolo GV generator. Power ratings from 4.3 kW – 12 kW per generator.

System example below:

DC generator system charging one 48 VDC battery – charge power 8.6 kW

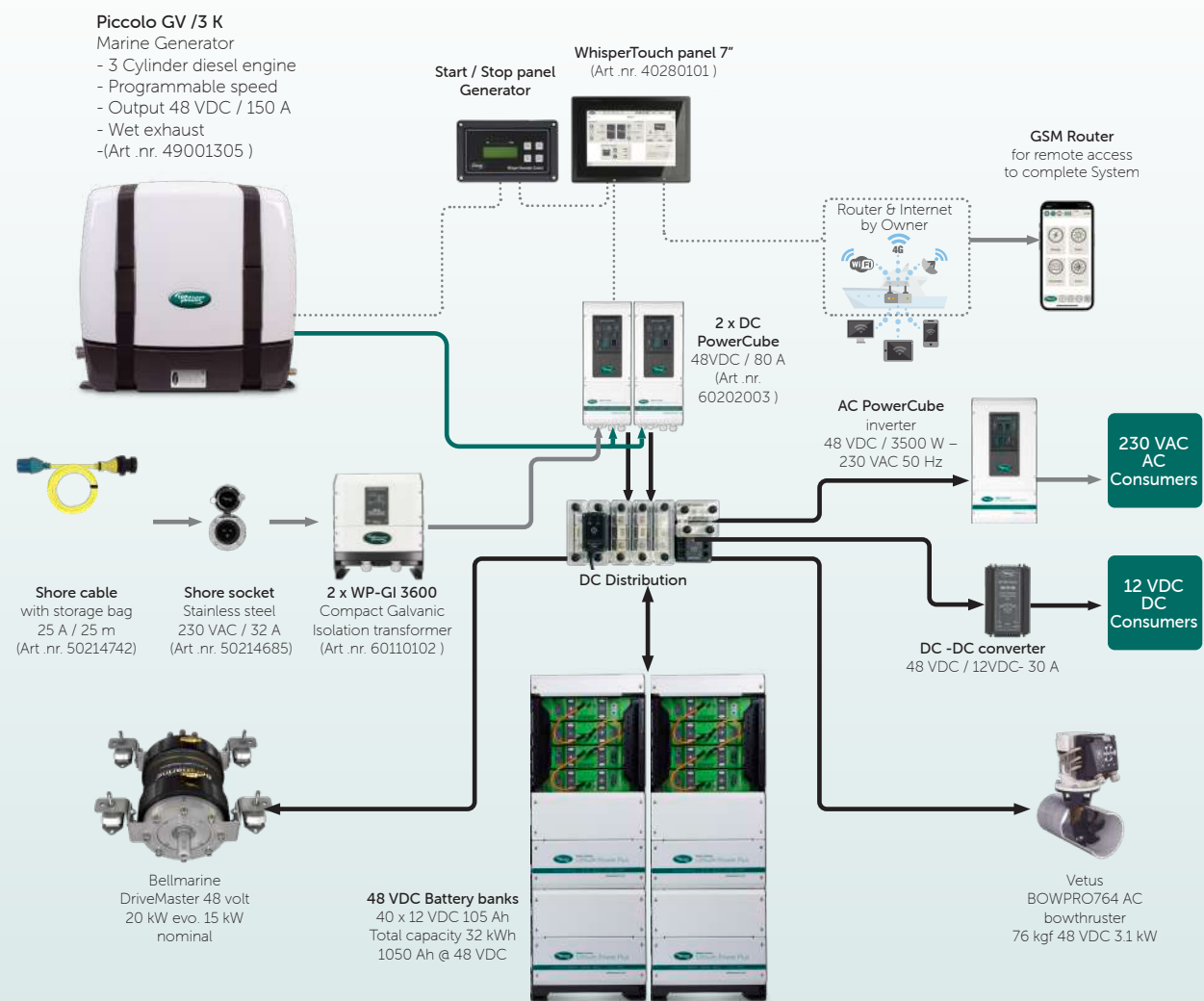

Full control on your DC Power system using WhisperCare

Having the ability to constantly monitor and control your system is essential. With WhisperCare, you can connect, manage and control your WhisperPower energy system on an installed touch panel in your vessel. WhisperCare can be seamlessly integrated into your existing MFDs, such as Raymarine and Garmin. Additionally, the OctoControl Pro can be used with the WhisperPower Touch Monitors to view and control your system.

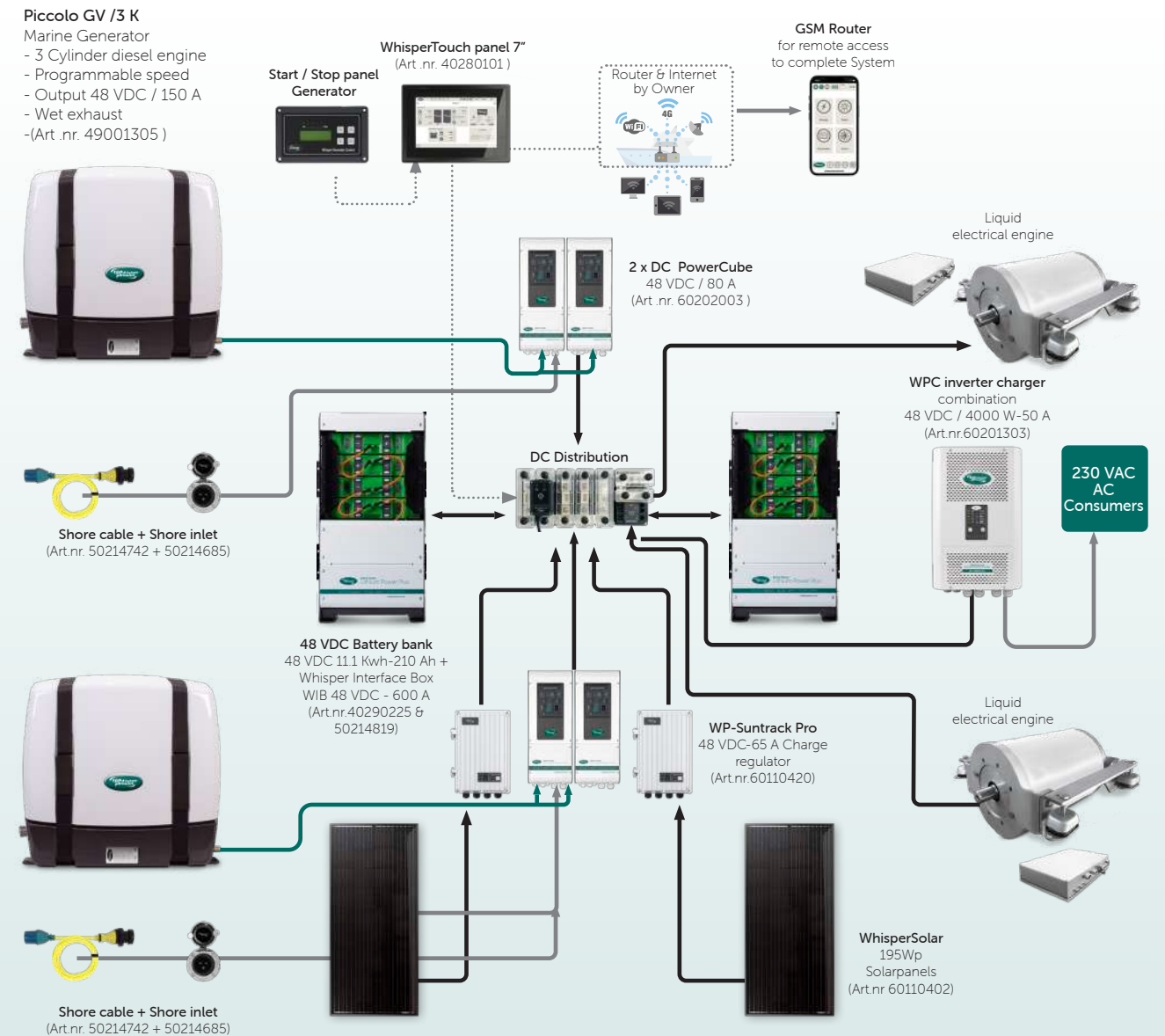

1500 / 1800 rpm models From 15 - 54 kVA Choose your power window

Over the past 20 years, Whisper generators have built a strong reputation. They are regarded to be durable and reliable power solutions, meeting the challenges of commercial and high-end recreational marine applications. While the high rpm 3000/3600 generators have been replaced by the quiet and compact Genverter series, our 1500/1800 fixed rpm range has undergone a major upgrade.



Advanced Classic Power Systems

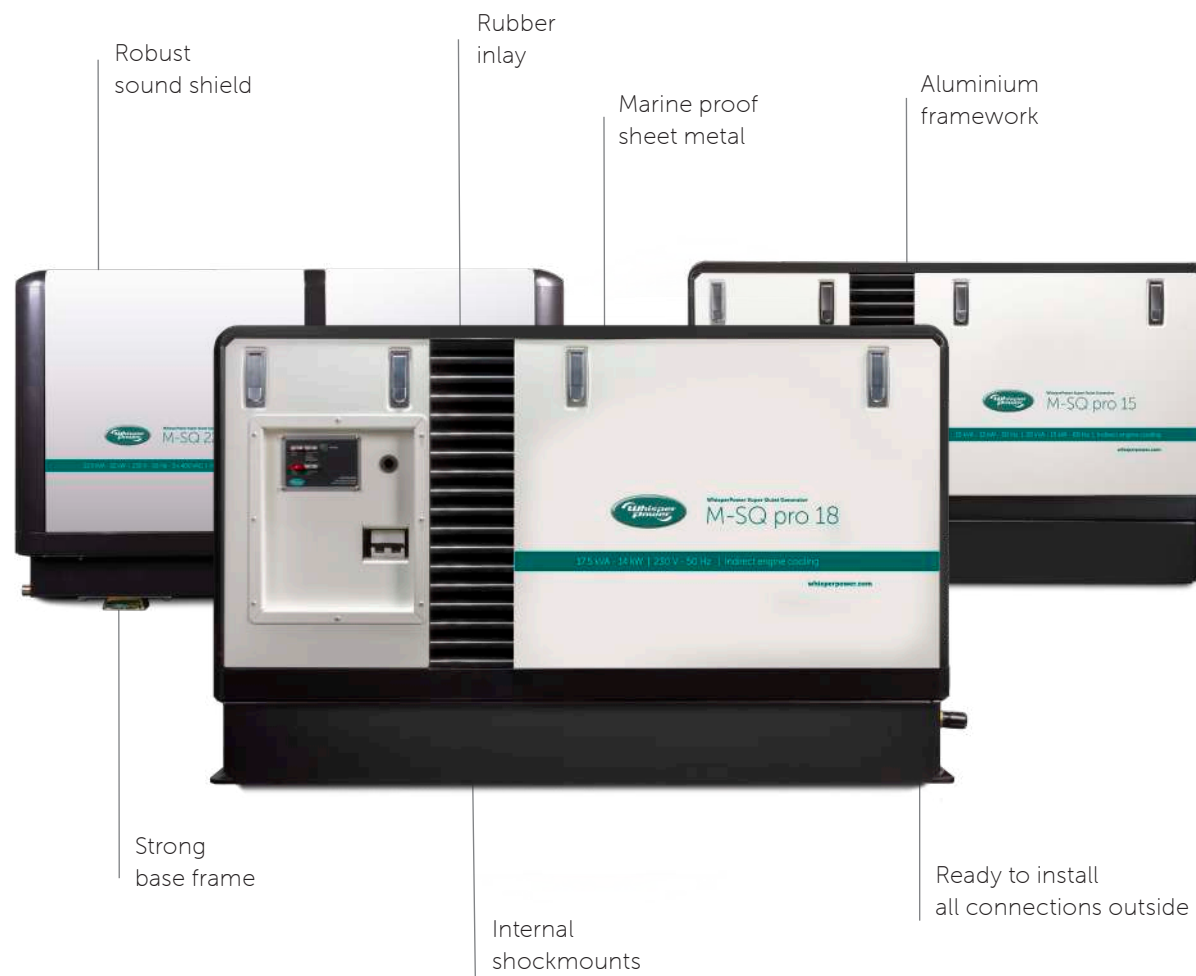

M-SQ system parallel configuration

Save costs on fuel and maintenance

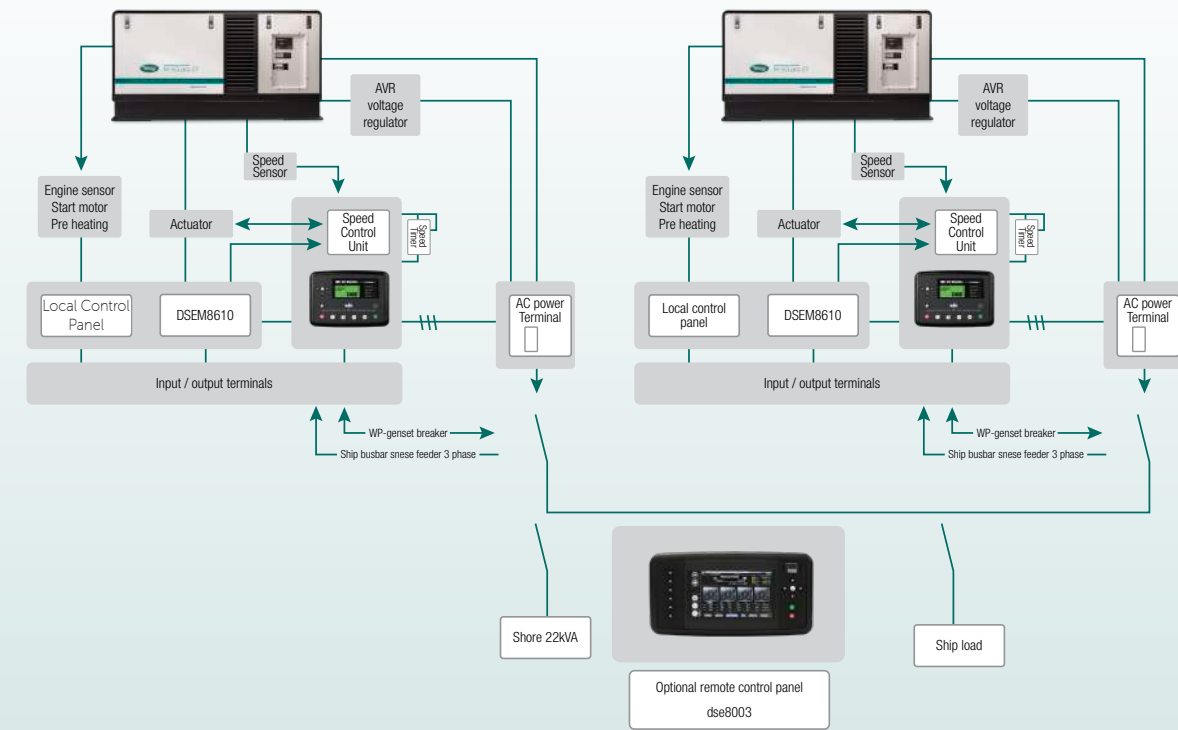

DDC Remote

DDC Remote panel as used in the past for our standard versions, still standard supply for our 1500 versions (excl.M-SQ 32)

- One touch start button
- V/A/Hz read-out
- Various user menus
- Automatic start/stop



From DDC to Deep Sea Controls

Important optional feature of our new SQ Pro range is the new 7 inch full colour Touch Screen Control which is easy to link to existing analogue or digital networks. Our traditional DDC controls are still used as standard.

Some key features and benefits of the new control & power management panels:

- Remote communications (RS232, RS485 x2, Ethernet)
- Genset parallel functionality included (ask for more detail)
- Provides secure and simple off site monitoring
- Front panel mounting
- Enables fault conditions to be resolved quickly and provides instant system information to aid preventative maintenance
- Graphical displays showing, charts, meters, power display, graphs and engine status information
- Information is displayed clearly and in a universal format for all users
- Language by choice

General Overview Diesel Generators

M-SQ Pro 1500 rpm



	M-SQ PRO 15 - STV	M-SQ PRO 15	M-SQ PRO 18 - STV	M-SQ PRO 18		M-SQ PRO 22.5	M-SQ ¹ PRO 25	M-SQ ³ PRO 27	M-SQ ³ PRO 32
	41207005 - STV (DDC) 1-phase	41207005 - (DDC) 1-phase	41208105 - STV (DDC) 1-phase	41208105 - (DDC) 1-phase		41101205 - 230 VAC / 50 Hz 22.5 kVA, 1-phase	41202005 - 230 VAC / 50 Hz 27 kVA *, 1-phase	41201305 - 230 - 400 V / 50 Hz 27 kVA, 3-phase	41201405 - 230 - 400 V / 50 Hz 32 kVA, 3-phase
	41207005 - STV-DSE (deepsea) 1-phase	41207005 - DSE (deepsea) 1-phase	41208105 - STV-DSE (deepsea) 1-phase	41208105 - DSE (deepsea) 1-phase		41101255 - 120 VAC-240 V / 60 Hz 25 kVA, 1-phase	41202006 - 230 VAC / 50 Hz 25 kW *, 1-phase		
	41207305 - STV (DDC) 3-phase	41207305 - (DDC) 3-phase	41208305-STV (DDC) 3-phase	41208305 - (DDC) 3-phase		41131205 - 230 - 400 V / 50 Hz 22.5 kVA, 3-phase	41202030 - 230 VAC / 50 Hz 25 kW *, 1-phase		
	41207305 - STV-DSE (deepsea) 3-phase	41207305 - DSE (deepsea) 3-phase	41208305 - STV-DSE (deepsea) 3-phase	41208305 - DSE (deepsea) 3-phase		41131255 - 120 - 240 V / 60 Hz 25 kVA, 3-phase			
MAIN SPECIFICATIONS									
Intermittent Power kW at 25°C (77°F)	12 kW	12.5 kW	14.5 kW	16.5 kW		22 kW	25 kW	25 kW	27 kW
Continuous power kVA at 25°C (77°F)	13.75 kVA	15 kVA	17.5 kVA	18.0 kVA		22.5 kVA	27 kVA	27 kVA	32 kVA
Continuous power kW at 25°C (77°F)	11 kW	12 kW	14 kW	16 kW		20 kW	22.5 kW	25 kW	27 kW
Noise level	55dB	55dB	55dB	55dB		58dB	58dB	58dB	58dB
RPM range	1500 rpm	1500 rpm	1500 rpm	1500 rpm		1500/1800 rpm	1500/1800 rpm	1500/1800 rpm	1500/1800 rpm
Cooling	Indirect watercooling	Indirect watercooling	Indirect watercooling	Indirect watercooling		Indirect watercooling	Indirect watercooling	Indirect watercooling	Indirect watercooling
Voltage Regulation	AVR	AVR	AVR	AVR		AVR	AVR + EBS	AVR + EBS	AVR + EBS
Nominal voltage /frequency 1 phase	230 VAC / 50 Hz	230 VAC / 50 Hz	230 VAC / 50 Hz	230 VAC / 50 Hz		230 VAC / 50 Hz	230 VAC / 50 Hz	N/A	N/A
Nominal voltage /frequency 3 phase	400/230 VAC 50 Hz	400/230 VAC 50/60 Hz	400/230 VAC 50 Hz	400/230 VAC 50 Hz		230 VAC / 50 Hz - 3x 400 VAC	N/A	230 VAC / 50 Hz - 3x 400 VAC	230 VAC / 50 Hz - 3x 400 VAC
Peak power 2 s	200 %	200 %	200 %	200 %		200 %	300 %	300 %	300 %
Harmonic distortion	< 3 %	< 3 %	< 3 %	< 3 %		< 3 %	< 3 %	< 3 %	< 2 %
Frequency tolerance	± 5 %	± 5 %	± 5 %	± 5 %		± 5 %	± 5 %	± 5 %	± 5 %
DIESEL ENGINE SPECIFICATIONS									
Type	Kubota V1505 BG	Kubota V1505 BG	Kubota V2203 M BG	Kubota V2203 M BG		Mitsubishi S4S	Mitsubishi S4S	Mitsubishi S4S	Mitsubishi S4S
Cylinder, quantity	4	4	4	4		4	4	4	4
Displacement, L	1.5	1.5	2.197	2.197		3.331	3.331	3.331	3.331
Bore, mm	78.0 x 78.4 mm	78.0 x 78.4 mm	87 x 92.4 mm	87 x 92.4 mm		94 x 120 mm	94 x 120 mm	94 x 120 mm	94 x 120 mm
DIMENSIONS & WEIGHT									
Length x width x height (cabinet)	1145 x 625 x 690 mm	1145 x 625 x 690 mm	1220 x 718 x 754 mm	1220 x 718 x 754 mm		1260 x 680 x 800 mm	1555 x 749 x 805 mm	1555 x 749 x 805 mm	1555 x 749 x 805 mm
Dry weight	410 kg	410 kg	495 kg	495 kg		580 kg	640 kg	640 kg	640 kg
Dry exhaust / wet exhaust	Ø 1 ½ inch / Ø 50 mm	Ø 1 ½ inch / Ø 50 mm	Ø 1 ½ inch / Ø 50 mm	Ø 1 ½ inch / Ø 50 mm		Ø 2 inch BSP / Ø 63 mm	Ø 2 inch BSP / Ø 63 mm	Ø 2 inch BSP / Ø 63 mm	Ø 2 inch BSP / Ø 63 mm
Max. operating angle	25° in all directions	25° in all directions	25° in all directions	25° in all directions		25° in all directions	25° in all directions	25° in all directions	25° in all directions
CONTROL PANEL									
Standard	DDC or Deepsea controller	DDC or Deepsea controller	DDC or Deepsea controller	DDC or Deepsea controller		DDC	DDC	DDC	Deepsea controller
Optional	WP-Touch full color panel 7"	WP-Touch full color panel 7"	WP-Touch full colour panel 7"	WP-Touch full colour panel 7"		WP-Touch full colour panel 7"			
	Ungrounded	Ungrounded	Ungrounded	Ungrounded		Ungrounded	Ungrounded	Ungrounded	Ungrounded
	Keel cooling	Keel cooling	Keel cooling	Keel cooling		Keel cooling	Keel cooling	Keel cooling	Keel cooling
	Crankcase heating	Crankcase heating	Crankcase heating	Crankcase heating		Crankcase heating	Crankcase heating	Crankcase heating	Crankcase heating
		60 Hz				60 Hz	60 Hz	60 Hz	60 Hz

*) Variations such as ungrounded/double pole, dry exhaust or keel cooling are available at request.

Go to our website to find our 60 Hz (North American) models



Diesel Generator M-SQ Pro 15



Available variations:

230 VAC | 50 Hz | 1 phase

- 12 kW DDC control
- 12 kW Deepsea control
- 13 kW DDC control
- 13 kW Deepsea control

230/400 VAC | 50 Hz | 3 phase

- 12 kW DDC control
- 12 kW Deepsea control
- 13 kW DDC control
- 13 kW Deepsea control

Dimensions M-SQ Pro 15

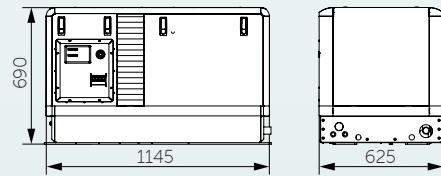

DDC remote control panel



	M-SQ PRO 15	
	Without Sound Shield	With Sound Shield
Weight kg (lb.) Wet	385 (848,8)	425 (937,0)
Weight kg (lb.) Dry	370 (815,7)	410 (904,0)
Length mm (in.)	984 (38,4)	1145 (45,1)
Width mm (in.)	462 (18,2)	625 (24,6)
Height mm (in.)	625 (24,6)	690 (27,2)
POWER OUTPUT	STAGE V	NON-STAGE V
Intermittent Power kW	12.5	12.5
Continuous power kVA at 25°C (77°C)	13.75	15
Continuous power kW at 25°C (77°C)	11	12
ENGINE SPECIFICATIONS		
Type	Kubota V1505 BG	
Cylinder quantity	4	
Displacement, L (cu. In.)	1.5 (91.5)	
Bore, mm (in.)	78.0 (3.07)	
Stroke, mm (in.)	78.4 (3.09)	
Compression ratio	23.0	
Combustion system	IDI	
Nominal speed, rpm	1500/1800	
Net Continuous power at rated rpm, kW (hp)	12.0 (16.4)	
Governor, type	Mechanical (±5%)	
Max. operating angle	20°	
ENGINE ELECTRICAL SYSTEM		
Battery, voltage	12 VDC	
Battery, charging module	40 A	
Battery, minimum recommendation	55 Ah	
Starter motor	12 VDC / 1.2 kW	
COOLING SYSTEM		
Capacity, L, approx..	4.0	
Heat extraction	Shell and Tube Countercurre	
Thermostat	Open at 76.6°C	
	Full open at 85°C	
FUEL SYSTEM		
Fuel shut off solenoid	Electrical (ETR)	
Fuel injection pump	In-Line pump	
Fuel lift pump	Facet Gold Flo	
LUBRICATION SYSTEM		
Oil pump type	Pressure	
Oil pan capacity with filter, L (gal.)	6.0 (1.6)	
OPERATION REQUIREMENTS	50 Hz	60 Hz
Engine Speed RPM	1500	1800
Air requirements, ft3/ min	53.0	63.6
Max, air intake restriction, kPa	2.45	2.94
Exhaust temp. At full load		
Max. allowed exhaust pressure, kPa	7.07	8.48
FUEL CONSUMPTION g/kWh	50 Hz	60 Hz
100% load	247	*

Optional: Crankcase heater, Keel cooling, Mass free



DDC
Digital Diesel Control Panel
Art. Nr. 40209102



Water inlet kit
20 mm (3/4")
Art. Nr. 40230211



Syphon breaker kit
20 mm (3/4")
Art. Nr. 40230273



Water lock exhaust kit
51/51 mm (2")
Art. Nr. 40230282

ACCESSORIES & OPTIONS FOR M-SQ PRO 15

Article number	Definition	
40209102	Optional 2 nd panel: DDC remote control panel: standard supplied with all Whisper Generator	
40230211	Water inlet kit 20 mm (3/4")	
40230273	Syphon breaker kit 20 mm (3/4")	
40230282	Water lock exhaust kit 51/51 mm (2")	
40230292	Water-gas separator kit 51/40/51 (2")	
40290031	Starter battery	AGM Power 12 VDC 100 Ah
40290108	Starter battery installation kit incl. Battery Charger	Handy 12 VDC 7 A
40230205	Universal fuel kit	



Water/Gas separator kit
51/40/51 (2")
Art. Nr. 40230292



Starter battery
AGM Power 12 VDC | 100 Ah
Art. Nr. 40290031



Starter battery installation kit
>100 Ah incl. Battery Charger
Handy 12 VDC | 7 A
Art. Nr. 40290108



Universal fuel kit
Art. Nr. 40230205

EXTRA ACCESSORIES FOR M-SQ PRO 15

Article number	Definition	
40222244	WPL-15W40 General, Lubricant oil, 4 liters	2 containers are required
40222214	WPL-Coolant G12+, 4 liters	2 containers are required
42401463	A-kit maintenance parts M-SQ Pro 15	
42401462	B-kit maintenance parts M-SQ Pro 15	



WPL-15W40
General, Lubricant oil, 4 liters
Art. Nr. 40222244



WPL-Coolant G12+
4 liters
Art. Nr. 40222214



A-kit maintenance parts
Art. Nr. 42401463



B-kit maintenance parts
Art. Nr. 42401462



Diesel Generator M-SQ Pro 18



Available variations:

230 VAC | 50 Hz | 1 phase

14.5 kW DDC control
14.5 kW Deepsea control
16.5 kW DDC control
16.5 kW Deepsea control

230/400 VAC | 50 Hz | 3 phase

14.5 kW DDC control
14.5 kW Deepsea control
16.5 kW DDC control
16.5 kW Deepsea control

Dimensions M-SQ Pro 18

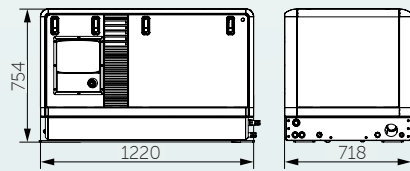

DDC remote control panel



	M-SQ PRO 18	
	Without Sound Shield	With Sound Shield
Weight kg (lb.) Wet	470 (1036,2)	510 (1124,4)
Weight kg (lb.) Dry	455 (1003,1)	495 (1091,3)
Length mm (in.)	999 (39,3)	1220 (48,0)
Width mm (in.)	568 (22,4)	719 (28,3)
Height mm (in.)	681 (26,8)	754 (29,7)
POWER OUTPUT		
	STAGE V	NON-STAGE V
Intermittent Power kW	14.5	16.5
Continuous power kVA at 25°C (77°C)	17.5	20
Continuous power kW at 25°C (77°C)	14	16
ENGINE SPECIFICATIONS		
Type	Kubota V2203 M BG	
Cylinder quantity	4	
Displacement, L (cu. In.)	2,197 (134)	
Bore, mm (in.)	87 (3,4)	
Stroke, mm (in.)	92,4 (3,6)	
Compression ratio	22.0	
Combustion system	IDI	
Nominal speed, rpm	1500 / 1800	
Net Continuous power at rated rpm, kW (hp)	17.2 (23.1)	
Governor, type	Mechanical (±5%)	
Max. operating angle	20°	
ENGINE ELECTRICAL SYSTEM		
Battery, voltage	12 VDC	
Battery, charging module	40 A	
Battery, minimum recommendation	80 Ah	
Starter motor	12 VDC / 1.4 kW	
COOLING SYSTEM		
Capacity, L, approx..	8.1	
Heat extraction	Shell and Tube Countercure	
Thermostat	Open at 76.6°C	
	Full open at 85°C	
FUEL SYSTEM		
Fuel shut off solenoid	Electrical (ETR)	
Fuel injection pump	In-Line pump	
Fuel lift pump	Facet Gold Flo	
Lubrication System		
Oil pump type	Pressure	
Oil pan capacity with filter, L (gal.)	7.6 (2.0)	
OPERATION REQUIREMENTS		
	50 Hz	60 Hz
Engine Speed RPM	1500	1800
Air requirements, ft3/ min	50.62	50.62
Max, air intake restriction, kPa	2.45	2.45
Exhaust temp. At full load		
Max. allowed exhaust pressure, kPa	10.7	10.7
FUEL CONSUMPTION g/kWh		
	50 Hz	60 Hz
100% load	235	235
Optional: Crankcase heater, Keel cooling, Mass free		



DDC
Digital Diesel Control Panel
Art. Nr. 40209102



Water inlet kit
25 mm (1")
Art. Nr. 40230221



Syphon breaker kit
25 mm (1")
Art. Nr. 40230274



Water lock exhaust kit
51/51 mm (2")
Art. Nr. 40230282

ACCESSORIES & OPTIONS FOR M-SQ PRO 18

Article number	Definition	
40209102	Optional 2 nd panel: DDC remote control panel: standard supplied with all Whisper Generator	
40230221	Water inlet kit 25 mm (1")	
40230274	Syphon breaker kit 25 mm (1")	
40230282	Water lock exhaust kit 51 mm (2")	
40230292	Water-gas separator kit 51 mm (2")	
40290062	Starter battery	AGM Power 12 VDC 145 Ah
40290108	Starter battery installation kit incl. Battery Charger	Handy 12 VDC 7 A
40230205	Universal fuel kit	



Water/Gas separator kit
51/40/51 (2")
Art. Nr. 40230292



Starter battery
AGM Power 12 VDC | 145 Ah
Art. Nr. 40290062



Starter battery installation kit
>100 Ah incl. Battery Charger
Handy 12 VDC | 7 A
Art. Nr. 40290108



Universal fuel kit
Art. Nr. 40230205

EXTRA ACCESSORIES FOR M-SQ PRO 18

Article number	Definition	
40222244	WPL-15W40 General, Lubricant oil, 4 liters	2 containers are required
40222214	WPL-Coolant G12+, 4 liters	3 containers are required
42401362	A-kit maintenance parts	
42401363	B-kit maintenance parts	



WPL-15W40
General, Lubricant oil, 4 liters
Art. Nr. 40222244



WPL-Coolant G12+
4 liters
Art. Nr. 40222214



A-kit maintenance parts
Art. Nr. 42401362



B-kit maintenance parts
Art. Nr. 42401363



Diesel Generator M-SQ 22.5



Available variations:

230 VAC | 50 Hz | 22.5 kW
120 VAC | 60 Hz | 22.5 kW

Dimensions M-SQ 22.5

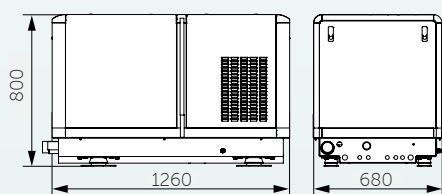

DDC remote control panel



	M-SQ PRO 22.5	
	Without Sound Shield	With Sound Shield
Dry weight kg (lb.)	580 (1278.0)	480 (1058.2)
Length mm (in.)	750 (29.5)	800 (1763.7)
Width mm (in.)	600 (23.6)	680 (1499.1)
Height mm (in.)	1150 (45.3)	1260 (2777.8)
RPM	1500 rpm	
Alternator	3 phase synchronous (air cooled)	
Engine	Mitsubishi diesel, model S4S (Japan)	
Number of cylinders	4	
Displacement	3331 cm ³	
Bore X stroke	94 x 122.5 mm	
Combustion air consumption	10 m ³ /min.	
Continuous power 50Hz	22.5 kVA/20.0 kW electric power	
Cooling system	indirect cooling by raw water, 22.5-25 l/min.	
Cooling water pump	PTO driven WhisperPower self-priming impeller pump, type M16	
Fuel lift pump engine	Mechanical pump, additional electrical pump available upon request	
Starting battery (optional)	12 VDC 40 Ah	
Fuel consumption	2-9 litre/hour, load dependent	
Control	Digital Diesel Control including automatic start/stop	
ELECTRICAL SPECIFICATIONS		
Output voltage	230/400 VAC 50 Hz alternating current (AC) tri phase re-connectable to take off single phase or dual voltage	
Output rating 50Hz	22.5 kVA /20 kw at power factor cos phi = 1	
Voltage tolerance	± 2% (balanced load)	
Frequency tolerance	± 3%	
Alternator	Air cooled, brushless, four pole, twelve wire, synchronous	
Voltage regulation:	AVR	
MECHANICAL SPECIFICATIONS		
Supply includes	Sound shield with steel base, mounted on rubber anti vibration mounts. (Genset without sound shield is optional)	
Colour:	metallic silver / grey	
Max. operation angle	25 degrees	
Standard supplies	Remote panel (+15 m cable), fuel filter, fuel lift pump, user and installation manuals	
Optional	Installation kits, mobile (vehicle) version, non-earth return, spare part kits, PTO to drive hydraulic pump	



ACCESSORIES & OPTIONS FOR M-SQ 22.5		
Article number	Definition	
40209102	Optional 2 nd panel: DDC remote control panel: standard supplied with all Whisper Generator	
40230221	Water inlet kit 25 mm (1")	
40230274	Syphon breaker kit 25 mm (1")	
40230225	Water lock exhaust kit 63 mm (2 1/2")	
40230224	Water-gas separator kit 63 mm (2 1/2")	
40290062	Starter battery	AGM Power 12 VDC 145 Ah
40290108	Starter battery installation kit incl. Battery Charger	Handy 12 VDC 7 A
40230205	Universal fuel kit	
40201894	Box cooler kit	keel cooling, dry exhaust
40201889	Dry exhaust kit 2"	keel cooling, dry exhaust



EXTRA ACCESSORIES FOR M-SQ 22.5		
Article number	Definition	
40222244	WPL-15W40 General, Lubricant oil, 4 liters	2 containers are required
40222214	WPL-Coolant G12+, 4 liters	3 containers are required
40201660	A-kit maintenance parts	
40201661	B-kit maintenance parts	



Diesel Generator M-SQ Pro 25



Available variations:
230 VAC | 50 Hz | 25 kW

Dimensions M-SQ Pro 25

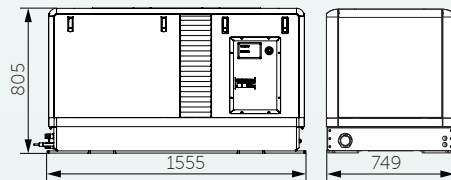

DDC remote control panel



DeepSea Control (optional)



	M-SQ PRO 25	
	Without Sound Shield	With Sound Shield
Wet Weight kg (lb.)	587 (1294)	680 (1499)
Dry weight kg (lb.)	567 (1250)	660 (1455)
Length mm (in.)	1440 (56.7)	1275 (50.2)
Width mm (in.)	749 (29.5)	595 (23.2)
Height mm (in.)	807 (31.7)	710 (27.9)
POWER OUTPUT	1 PHASE	2 PHASE
Intermittent Power kW	23	25
Continuous power kva at 25°C (77°C)	27	27
Continuous power kW at 25°C (77°C)	22	22.5
ENGINE SPECIFICATIONS		
Type	Mitsubishi S4S	
Cylinder quantity	4	
Displacement, L (cu. In.)	3,331 (203,3)	
Bore, mm (in.)	94 (3,7)	
Stroke, mm (in.)	120 (4,7)	
Compression ratio	22.0	
Combustion system	IDI	
Nominal speed, rpm	1500	
Net Continuous power at rated rpm, kW (hp)	28,3 (38,5)	
Governor, type	Mechanical (±5%)	
Max. operating angle	15°	
ENGINE ELECTRICAL SYSTEM		
Battery, voltage	12 VDC	
Battery, charging module	50 A	
Battery, minimum recommendation	145 Ah	
Starter motor	12 VDC / 2.2 kW	
COOLING SYSTEM		
Capacity, L, approx..	5.5	
Heat extraction	Shell and Tube Countercure	
Thermostat	Open at 76.6°C	
	Full open at 85°C	
FUEL SYSTEM		
Fuel shut off solenoid	Electrical (ETR)	
Fuel injection pump	In-Line pump	
Fuel lift pump	NA	
LUBRICATION SYSTEM		
Oil pump type	Pressure	
Oil pan capacity with filter, L (gal.)	9.3 (2.5)	
OPERATION REQUIREMENTS 50 Hz		
Engine Speed RPM	1500	
Air requirements, ft3/ min	353	
Max, air intake restriction, kPa	1.96	
Exhaust temp. At full load		
Max. allowed exhaust pressure, kPa	6.57	
FUEL CONSUMPTION g/kWh 50 Hz		
100% load	302	
Optional: Crankcase heater, Keel cooling, Mass free		



ACCESSORIES & OPTIONS FOR M-SQ PRO 25		
Article number	Definition	
40209102	Optional 2 nd panel: DDC remote control panel: standard supplied with all Whisper Generator	
40230221	Water inlet kit 25 mm (1")	
40230274	Syphon breaker kit 25 mm (1")	
40230225	Water lock exhaust kit 63 mm (2 1/2")	
40230224	Water-gas separator kit 63 mm (2 1/2")	
40290062	Starter battery	AGM Power 12 VDC 145 Ah
40290108	Starter battery installation kit incl. Battery Charger	Handy 12 VDC 7 A
40230205	Universal fuel kit	
40201894	Box cooler kit	keel cooling, dry exhaust
40201889	Dry exhaust kit 2"	keel cooling, dry exhaust

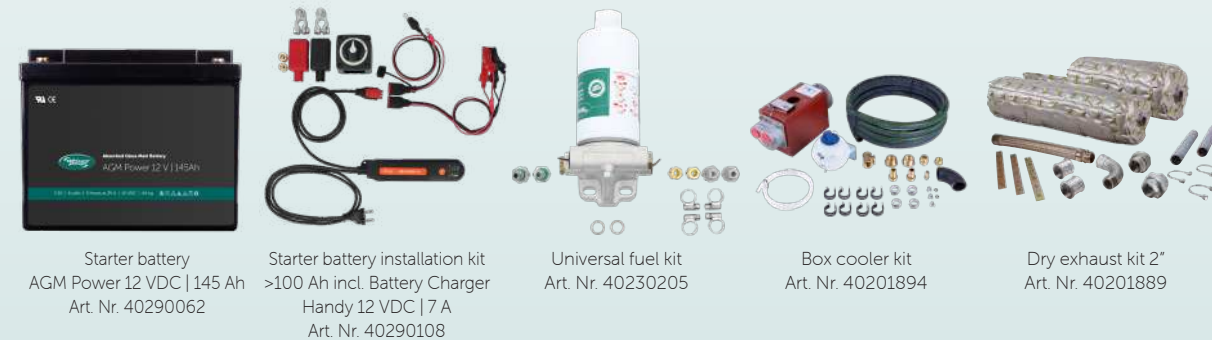

EXTRA ACCESSORIES FOR M-SQ PRO 25		
Article number	Definition	
40222244	WPL-15W40 General, Lubricant oil, 4 liters	2 containers are required
40222214	WPL-Coolant G12+, 4 liters	3 containers are required
40201660	A-kit maintenance parts	
40201661	B-kit maintenance parts	





Diesel Generator M-SQ Pro 27



Available variations:

230/400 VAC | 50 Hz | 3 phase
 25 kW
 25 kW ungrounded
 25 kW keel cooling

Dimensions M-SQ Pro 27

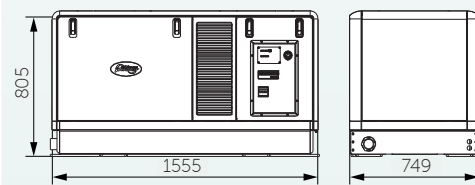

DDC remote control panel



DeepSea Control (optional)



	M-SQ PRO 27	
	Without Sound Shield	With Sound Shield
Dry weight kg (lb.)	550 (1212)	660 (1411)
Length mm (in.)	1400 (55.1)	1555 (61.2)
Width mm (in.)	730 (28.7)	805 (31.7)
Height mm (in.)	600 (23.6)	749 (29.5)
RPM	1500 rpm	
Alternator	3 phase synchronous (air cooled)	
Engine	Mitsubishi diesel, model S4S (Japan)	
Number of cylinders	4	
Displacement	3331 cm ³	
Bore X stroke	94x120 mm	
Combustion air consumption	10 m ³ /min.	
Continuous power 50Hz	20 kW electric power	
Cooling system	indirect cooling by raw water, 20-25 l/min.	
Cooling water pump	PTO driven WhisperPower self-priming impeller pump, type M16	
Fuel lift pump engine	Mechanical pump, additional electrical pump available upon request	
Starting battery (optional)	145 Ah 12 VDC	
Fuel consumption	2-9 litre/hour, load dependent	
Control	Digital Diesel Control including automatic start/stop	

ELECTRICAL SPECIFICATIONS

Output voltage	230/400 VAC 50 Hz alternating current (AC) tri phase re-connectable to take off single phase or dual voltage
Output rating 50 Hz	20 kVA at power factor cos phi = 1
Voltage tolerance	± 2% (balanced load)
Frequency tolerance	± 3%
Alternator	Air cooled, brushless, four pole, twelve wire, synchronous
Voltage regulation:	AVR

MECHANICAL SPECIFICATIONS

Supply includes	Sound shield with steel base, mounted on rubber anti vibration mounts. (Genset without sound shield is optional)
Colour:	metallic silver / grey
Max. operation angle	25 degrees
Standard supplies	Remote panel (+15 m cable), fuel filter, fuel lift pump, user and installation manuals
Optional	Installation kits, mobile (vehicle) version, non-earth return, spare part kits, PTO to drive hydraulic pump



ACCESSORIES & OPTIONS FOR M-SQ PRO 27

Article number	Definition	
40209102	Optional 2 nd panel: DDC remote control panel: standard supplied with all Whisper Generator	
40230221	Water inlet kit 25 mm (1")	
40230274	Syphon breaker kit 25 mm (1")	
40230225	Water lock exhaust kit 63 mm (2 1/2")	
40230224	Water-gas separator kit 63 mm (2 1/2")	
40290062	Starter battery	AGM Power 12 VDC 145 Ah
40290108	Starter battery installation kit incl. Battery Charger	Handy 12 VDC 7 A
40230205	Universal fuel kit	
40201894	Box cooler kit	keel cooling, dry exhaust
40201889	Dry exhaust kit 2"	keel cooling, dry exhaust

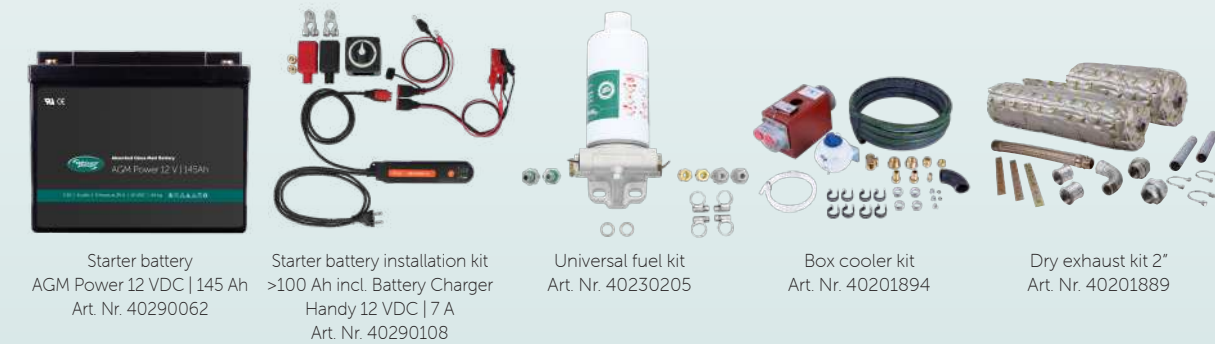

EXTRA ACCESSORIES FOR M-SQ PRO 27

Article number	Definition	
40222244	WPL-15W40 General, Lubricant oil, 4 liters	2 containers are required
40222214	WPL-Coolant G12+, 4 liters	3 containers are required
40201660	A-kit maintenance parts	
40201661	B-kit maintenance parts	





Diesel Generator M-SQ Pro 32



Available variations:

230 - 400 VAC | 50 Hz | 27 kW
120 - 240 VAC | 60 Hz | 30 kW

Dimensions M-SQ Pro 32

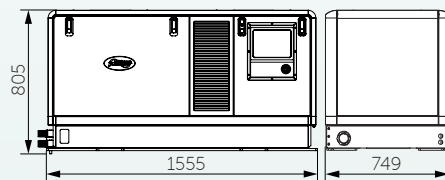

DeepSea Control (standard)



DeepSea Control (optional)



	M-SQ PRO 32	
	Without Sound Shield	With Sound Shield
Dry weight kg (lb.)	550 (1212)	660 (1455)
Length mm (in.)	1400 (61.2)	1555 (61.2)
Width mm (in.)	730 (31.7)	805 (31.7)
Height mm (in.)	600 (29.5)	749 (29.5)
Intermittent Power kW at 25°C (77°F)	27 kW	
Continuous Power kVA at 25°C (77°F)	32 kVA	
Noise level	58 dB	
RPM range	1500 / 1800 rpm	
Cooling	Indirect water cooled	
Alternator voltage regulation	AVR + EBS, forced ventilation	
Nominal voltage / frequency	400-230 VAC, 3 ph, 50 Hz (60 Hz)	
Peak power 2 s	300%	
Harmonic distortion	< 2%	
Frequency tolerance	± 5 %	
DIESEL ENGINE SPECIFICATIONS		
Engine	WhisperPower Mitsubishi S4S	
Number of cylinders	4	
Cylinder volume	3331 cc	
Bore & stroke, mm (in.)	94 x 120 (3.7 x 4.7)	
Air consumption	2.8m ³ /min	
Cooling system	indirect	
Fuel consumption (no load - full load)	1-6 l/hr	
starter battery charge current	12 VDC / 40 A	
Dry exhaust / wet exhaust	Ø 2 inch BSP / Ø 63 mm	
Oil dipstick	Top & side	
Max. operating angle	25° in all directions	



Service side of the M-SQ Pro 32

Engine compartment is separated from the alternator compartment to enhance audible noise reduction



ACCESSORIES & OPTIONS FOR M-SQ PRO 32		
Article number	Definition	
50208053	Remote control panel DSE display	
40230221	Water inlet kit 25 mm (1")	
40230274	Syphon breaker kit 25 mm (1")	
40230225	Water lock exhaust kit 63 mm (2½")	
40230224	Water-gas separator kit 63 mm (2½")	
40290062	Starter battery	AGM Power 12 VDC 145 Ah
40290108	Starter battery installation kit incl. Battery Charger	Handy 12 VDC 7 A
40230205	Universal fuel kit	
40201894	Box cooler kit	keel cooling, dry exhaust
40201889	Dry exhaust kit 2"	keel cooling, dry exhaust



EXTRA ACCESSORIES FOR M-SQ PRO 32		
Article number	Definition	
40222244	WPL-15W40 General, Lubricant oil, 4 liters	2 containers are required
40222214	WPL-Coolant G12+, 4 liters	3 containers are required
40201660	A-kit maintenance parts	
40201661	B-kit maintenance parts	



WhisperPower Exhaust Systems

For a safe and quiet system

Pairing your generator with our WhisperPower exhaust system adds a fit for purpose and professional finishing touch in much the same way that the WhisperPower installation kits ensure correct and professional installation. They have been specifically designed for our WhisperPower generators to manage engine noise and separate exhaust gas from the cooling water. Our exhaust kits are composed as follows:

- The WhisperPower silencers / water locks are designed for engines and generators positioned below the waterline. They protect the engine against the return flow of cooling water. An important additional feature is the noise reduction of the engine
- The WhisperPower water / gas separator is designed to remove the exhaust fumes from the cooling water via two outlets: one above the waterline for fumes and one to discharge the cooling water. As a result, there is a considerable reduction in exhaust noise with no splash noise
- The WhisperPower exhaust components are made from fire proof GRP and fully comply with ABYC regulations
- The kits include hoses (certified to ISO 13363/ marine use), heavy duty hose clamps, seacocks and through-hull fittings



Water / Gas Separator

Available as a complete kit with hoses, seacocks and through-hull fittings or as separate silencer / water lock.

Silencer / Water lock

Available as a complete kit or as separate silencer / water lock in three sizes. Suitable for all engines or standard generators from 3 kW-30 kW



Water / Gas Separator

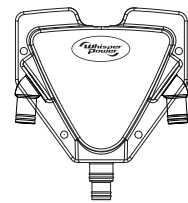

Available as:

Art. Nr. 40230087
40-40-40 mm
(1 5/8" - 1 5/8" - 1 5/8")
370 x 165 x 417 mm

Art. Nr. 40230088
51-40-51 mm
(2" - 1 5/8" - 2")
370 x 165 x 417 mm

Silencer / Water lock

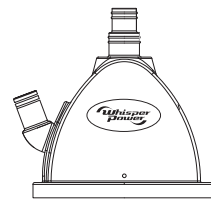

Available as:

Art. Nr. 40230083
40-40 mm (1 5/8")
310 x 210 x 310 mm

Art. Nr. 40230084
51-51 mm (2")
310 x 210 x 310 mm

WHISPER POWER WATERLOCK/GAS SEPARATOR (PLASTIC)

Art.Nr.	Model	Size
40230083	WP-WL 40/40 Silencer/waterlock	40 mm
40230281	WP-WL 40/40/40 Silencer/waterlock exhaust kit (1 5/8")	40 mm
40230087	WP-WGS 40/40/40 Water/Gas separator (1 5/8")*	40 mm
40230291	WP-WGS 40/40 Water/Gas separator kit (1 5/8")*	40 mm
40230084	WP-WL 51/51 Silencer/waterlock	51 mm
40230292	WP-WL 51/51 Water/Gas separator kit (2")*	51 mm
40230282	WP-WL 51/51 Silencer/waterlock exhaust kit (2")	51 mm
40230088	WP-WGS 51/40/51 Water/Gas separator (2")*	51 mm
40230225	WP-WL 63/63 Silencer/waterlock exhaust kit (2 1/2")	63 mm

* Kits with plastic thru-hull for aluminium or carbon hull available at request



Service Kits

from WhisperPower

The A-kit contains all the spare parts for those items, such as filters and belts, that should be replaced on a regular basis. We advise always ordering an A-kit along with you new WhisperPower generator. The B-kit consists of parts for those items which may need to be replaced after a longer period of time, depending on the number of operating hours. Our B-kits include a larger number of components such as seals and various mechanical parts. For long trips, it is advisable to take a B-kit with you on board.

SERVICE KITS FOR MARINE USE

40401170	A-kit M-GV4 / Piccolo 4/5
40401171	B-kit M-GV4 / Piccolo 4/5
40401770	A-kit M-GV 2/3, M-GV 6/8/10/12 K
40401771	B-kit M-GV 2, M-GV 6/8 K
40401772	B-kit M-GV 3, M-GV 10/12 K
40401863	A-kit M-GV 3+, M-GV 15/18
40401864	B-kit M-GV 3+, M-GV 15/18
42401463	A-kit M-SQ 15 - 1500 / 1800 rpm
42401462	B-kit M-SQ 15 - 1500 / 1800 rpm
42401362	A-kit M-SQ 18 - 1500 / 1800 rpm
42401363	B-kit M-SQ 18 - 1500 / 1800 rpm
40201660	A-kit M-SQ 20/22.5/25/27/32 - 1500 / 1800 rpm
40201661	B-kit M-SQ 20/22.5/25/27/32 - 1500 / 1800 rpm

WPL COOLANT AND ENGINE OIL

40222214	WPL Coolant G12, Coolant, 4 liters
40222244	WPL 15 W40 General, Engine oil, 4 liters
40222221	WPL 15 W40 Premium Long Drain, Engine oil, 1 liters



Don't Forget
to order our
lubricants
& fluids



Spare Parts

Silencer/Waterlock

Available variations:

40/40
51/51



IMPORTANT INSTALLATION PARTS

Article number	Definition	
40230083	Silencer/waterlock 40/40	40 mm, synthetic material
40230084	Silencer/waterlock 51/51	51 mm, synthetic material

Spare Parts

Water-Gas Separator

Available variations:

40/40/40
51/40/51



IMPORTANT INSTALLATION PARTS

Article number	Definition	
40230087	Water-gas separator 40/40/40	40 mm, synthetic material
40230088	Water-gas separator 51/40/51	51 mm, synthetic material

Spare Parts

Marine fuel hose for diesel

Available variations:

8 x 16 mm | drum 20 m



IMPORTANT INSTALLATION PARTS

Article number	Definition	
50220063	Marine fuel hose for diesel	8 x 16 mm (drum 20 m)

Spare Parts

Exhaust Hose

Available variations:

(15/8") | 40 mm Ø
(2") | 51 mm Ø
(2 1/2") | 63 mm Ø



IMPORTANT INSTALLATION PARTS

Article number	Definition	
50220033	Exhaust hose (1 5/8")	40 mm Ø (inner diameter)
50220035	Exhaust hose (2")	51 mm Ø (inner diameter)
50220036	Exhaust hose (2 1/2")	63 mm Ø (inner diameter)

Spare Parts

Transparent Coolant Hose

Available variations:

13 x 19 mm | drum 20 m
19 x 26 mm | drum 20 m
25 x 33 mm | drum 20 m



IMPORTANT INSTALLATION PARTS

Article number	Definition	
50220055	Transparent coolant hose with metal spiral	13 x 19 mm (drum 20 m)
50220056	Transparent coolant hose with metal spiral	19 x 26 mm (drum 20 m)
50220050	Transparent coolant hose with metal spiral	25 x 33 mm (drum 20 m)

Spare Parts

Transparent Coolant Hose

Available variations:

13 x 21 mm | drum 20 m
18 x 26 mm | drum 20 m
25 x 34 mm | drum 20 m
32 x 41 mm | drum 20 m



IMPORTANT INSTALLATION PARTS

Article number	Definition	
50220057	Rubber flexible coolant hose (1/2")	13 x 21 mm (drum 20 m)
50220011	Rubber flexible coolant hose (3/4")	18 x 26 mm (drum 20 m)
50220012	Rubber flexible coolant hose (1")	25 x 34 mm (drum 20 m)
50220013	Rubber flexible coolant hose (1 1/4")	32 x 41 mm (drum 20 m)

Spare Parts

Battery Cable Red/Black

Available variations:

Red	Black
16 mm ² drum 50 m	16 mm ² drum 50 m
25 mm ² drum 25 m	25 mm ² drum 25 m
35 mm ² drum 25 m	35 mm ² drum 25 m







IMPORTANT INSTALLATION PARTS

Article number	Definition	
50213070	Battery cable Red	16 mm ² (drum 50 m)
50213071	Battery cable Black	16 mm ² (drum 50 m)
50213075	Battery cable Red	25 mm ² (drum 25 m)
50213076	Battery cable Black	25 mm ² (drum 25 m)
50213085	Battery cable Red	35 mm ² (drum 25 m)
50213086	Battery cable Black	35 mm ² (drum 25 m)



Monitoring & Control Remote Panels



	Genverter control Standard supply	DDC remote control panel Art. Nr. 40209102	DeepSea Control (optional)	WhisperTouch (optional) Not with DSE Generators			
			 Art. Nr. 50208053  Art. Nr. 50208054				
MODEL Art. Nr.			2510 MKII 50208054	8003 MKII 50208053	5" 40280105	7" 40280101	10" 40280102
Piccolo 2		■				□	□
Piccolo 3		■				□	□
Piccolo 3+		■				□	□
Piccolo 4	■				□	□	□
Piccolo 5	■				□	□	□
Piccolo 6	■					□	□
Piccolo 8		■				□	□
Piccolo 10		■				□	□
Piccolo 12		■				□	□
Piccolo 15		■				□	□
Piccolo 18		■				□	□
M-SQ Pro 15		■	□	□		□	□
M-SQ Pro 18		■	□	□		□	□
M-SQ 22.5		■				□	□
M-SQ Pro 25		■	□	□		□	□
M-SQ Pro 27		■	□	□		□	□
M-SQ Pro 32			□	■		□	□

■ = Standard □ = Optional

The Company

WhisperPower was founded in 2007 for the manufacturing of diesel generators and related items. Up to 2010 these products were sold under the Mastervolt brandname. Since then, the company has quickly and successfully grown and developed especially in terms of innovation and quality.

In 2009 Hybrid Power Systems BV was founded to develop and produce combined hybrid power and propulsion systems for superyachts and commercial vessels. Since 2010, the product portfolio has been significantly expanded with products and components which form complete electrical systems for vehicles, vessels or locations which do not have (permanent) connection to the public grid. They can be assembled for Plug and Play solutions.

WhisperPower has used its years of experience in developing systems containing a diesel engine to develop in-house, a new generation of power electronics. The product range covers power range options from 500 W to 500 kW.



In-house production

A large proportion of WhisperPower's production takes place in a modern 5500 m² factory in the Netherlands where work is done in accordance with ISO standards. Each integrated diesel product is tested extensively (3 hours) and receives a test certificate.

International Network

A comprehensive network of national and international dealers, installers and distributors ensures that WhisperPower products and systems find their way to the end user. In many countries, the network operates from an established WhisperPower commercial site. Service and warranty come first for us! For an overview of our network, please go to: www.whisperpower.com/where-to-buy

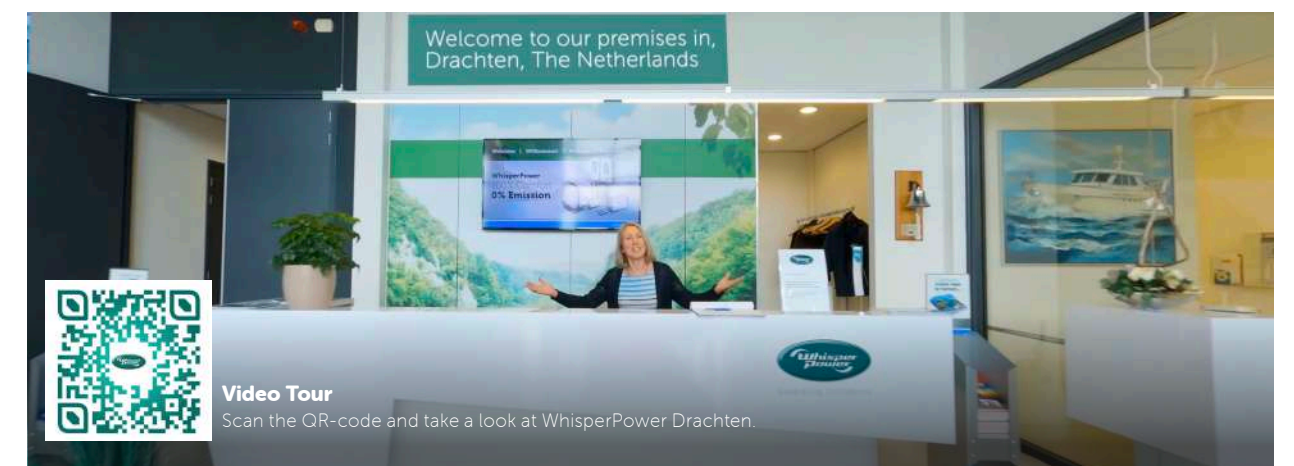

Video Tour

Scan the QR-code and take a look at WhisperPower Drachten.

Delivered anywhere, anytime

WhisperPower Service & Support

At WhisperPower, service and support goes beyond production and sales. We are and happily remain responsible for our products, systems and accessories. You can therefore count on all the necessary service and support both before and after your purchase. From initial system advice through to installation and from commissioning to outstanding maintenance and warranty support, first class service is our aim and priority.

System advice and design focused on your specific needs

Our engineers and advisers have extensive experience in the development and implementation of electrical systems.

They take pride in helping you make the right plans for your system's exact needs, be it the installation of a Genverter® or generator or more comprehensive and complex systems. We design a fit for purpose system with optimum efficiency. This hard and fast rule also applies if you are combining a generator system with, for example, an inverter, battery charger or solar or wind power.

Global Sales and Distribution network

The ever growing WhisperPower network of dealers and distributors can be found all over the world. Our international brand is locally represented by sales and distribution partners and importers. Specialists in their field, well-trained across the product range and professional, they are on hand and happy to assist for mobile, maritime and domestic applications.

Commissioning and System set up

Once delivered, WhisperPower's technical team also takes care of the installation and commissioning of the generator system where possible. In some countries - including the Benelux region - this service is included. You can, therefore, rest assured that your system is installed according to the appropriate guidelines and terms and conditions. For more information on the terms and conditions, please contact us.

Service & Support

In case of malfunction or repair, our technical representatives from our global network will provide you with service and technical support for repairs or malfunctions. Where possible, support and service work will be carried out on-site. This applies worldwide.

Regular training: up-to-date expertise

Knowledge and expertise form the foundation for the best possible service. Every WhisperPower technical sales partner has up-to-date knowledge and the benefit of our global experience. Regular training courses ensure our specialists stay abreast with and well informed about all of our products, both in terms of systems and applications. You can, therefore, be certain that WhisperPower offers far more than a box with a device: we offer you our expertise as standard.

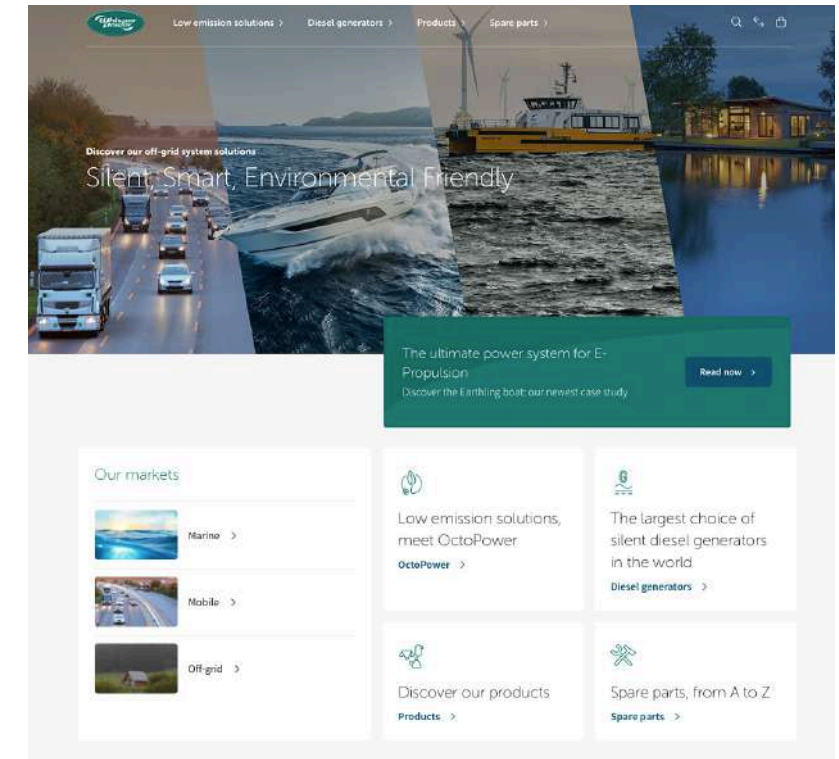

Minimal downtime during repairs

We have mobile service partners active in every conceivable region. To keep down time to a minimum, trouble shooting and repair work are carried out on-site. If needed, we will supply a replacement system to ensure continuous operation is maintained.

Up-to-date product specifications

Detailed specifications of the WhisperPower products can be found on our website and throughout this brochure and other printed product information. As we continuously strive to improve our products, specifications can be subject to change without prior notice.

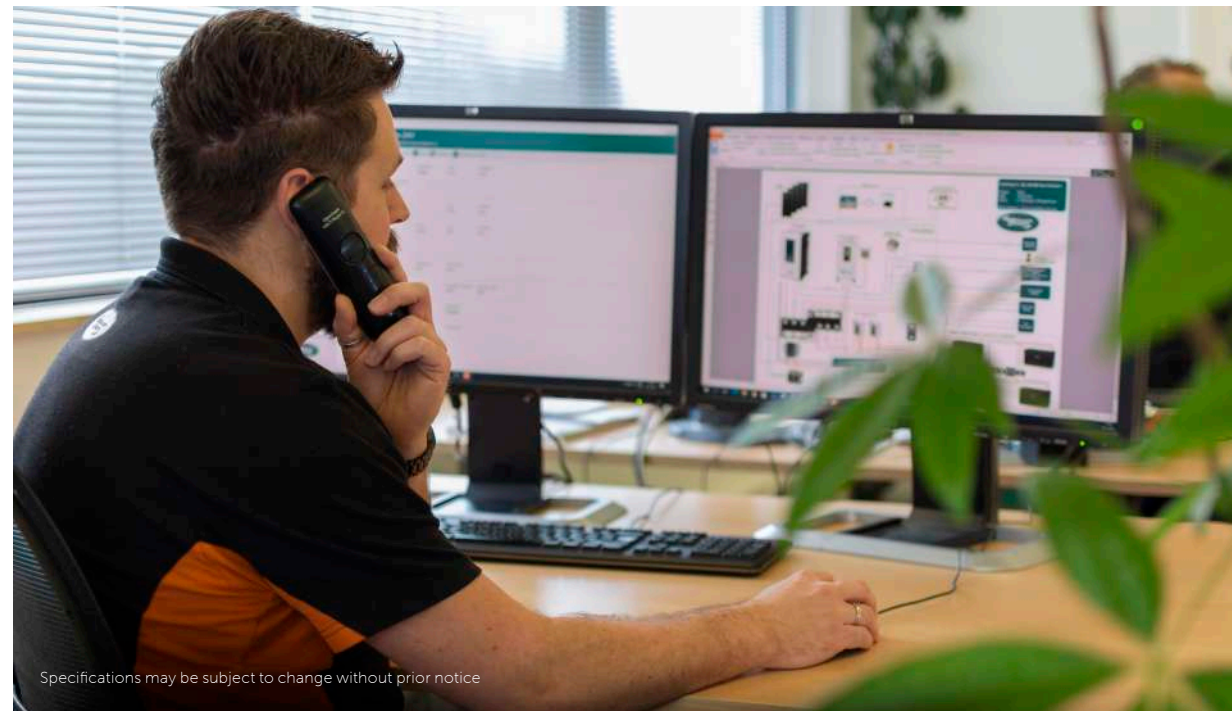

Specifications may be subject to change without prior notice

The WhisperPower Warranty Plan

When purchasing our products and systems, you always have the certainty of a dedicated WhisperPower WarrantyPlan. This plan covers as standard the costs of repairs and/or replacement of defective parts when products are used in 'normal' circumstances. The conditions for the WhisperPower WarrantyPlan are specific to the product and the use thereof in your system. The standard warranty term for equipment is two years. With an authorised system installations maintenance contract, the warranty term can be extended to five years. For electronic equipment and components, the standard product warranty is 5 years.

With sales in over 50 countries we make sure our distributors, dealers and installers serve you well;

- Extended system advice
- Selection of the right parts
- Installation of the system or generator
- Commissioning after installation
- Maintenance training
- Repair in case of a defect
- Software updates, when needed
- All our efforts are aiming to reduce unnecessary downtime.

Marine • Mobile • Land | www.whisperpower.com

OctoPower

1 kW 3 kW 6 kW 7 kW 14 kW 16 kW 32 kW

Concept explained

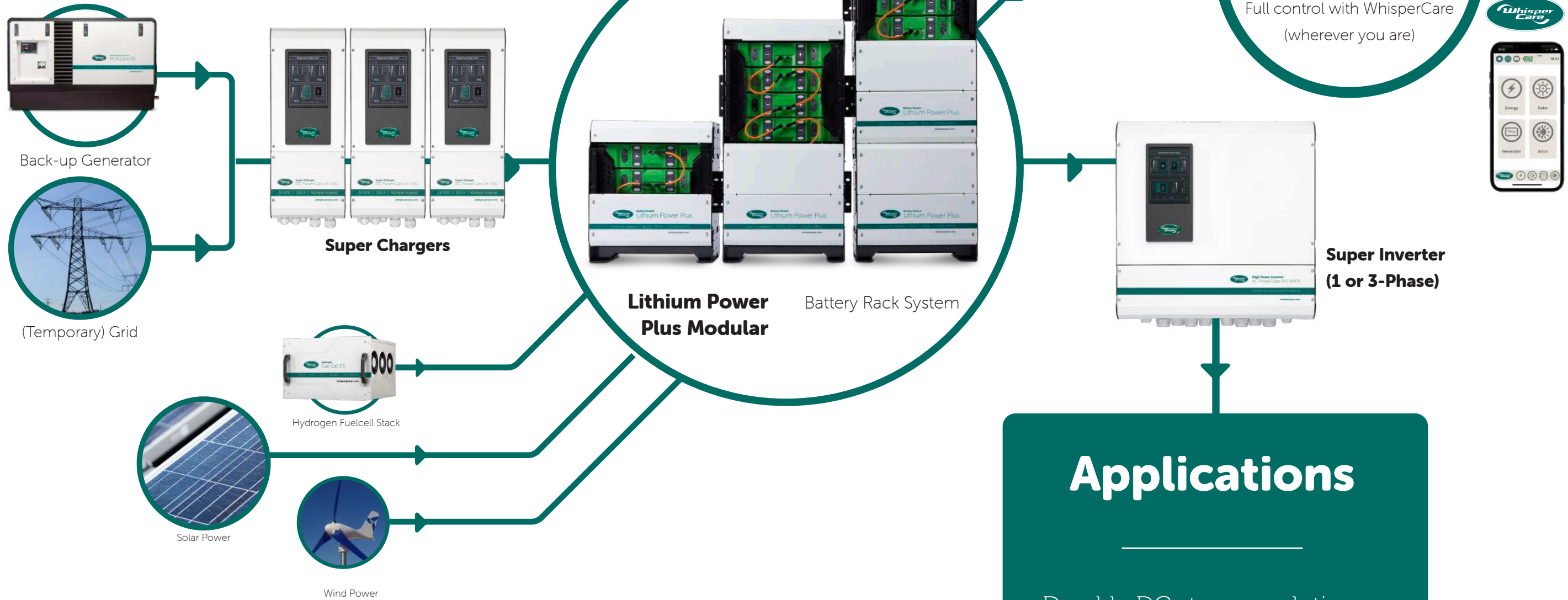

Applications

- Durable DC storage solution
- Generator emission reduction
- Peakshaving for power systems
- Electrical power for e-mobility
- Electrical power for e-propulsion

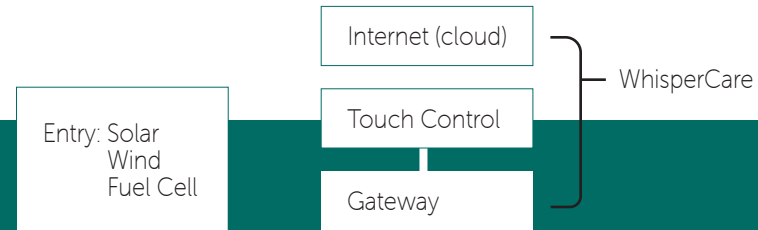

Hardware



OctoPower 3 kW

"Generator without engine"



Solar



Out- or inboard engine



Shore- Grid power



Power-Electronics Pack



Lithium-Battery Pack

- 3.8 kWh
- 5.1 kWh
- 7.6 kWh
- 10.2 kWh

ASK FOR A QUOTATION

Pure Sinewave AC Power



Air-conditioning

Cooking Hob

Comfort Equipment

Go to our website to learn more about our hybrid style power systems.

whisperpower.com

(English/ German/Spanish/French/Italian/Dutch) Available documentation



(English/ German/Spanish/French/Italian/Dutch) Visit our website(s)

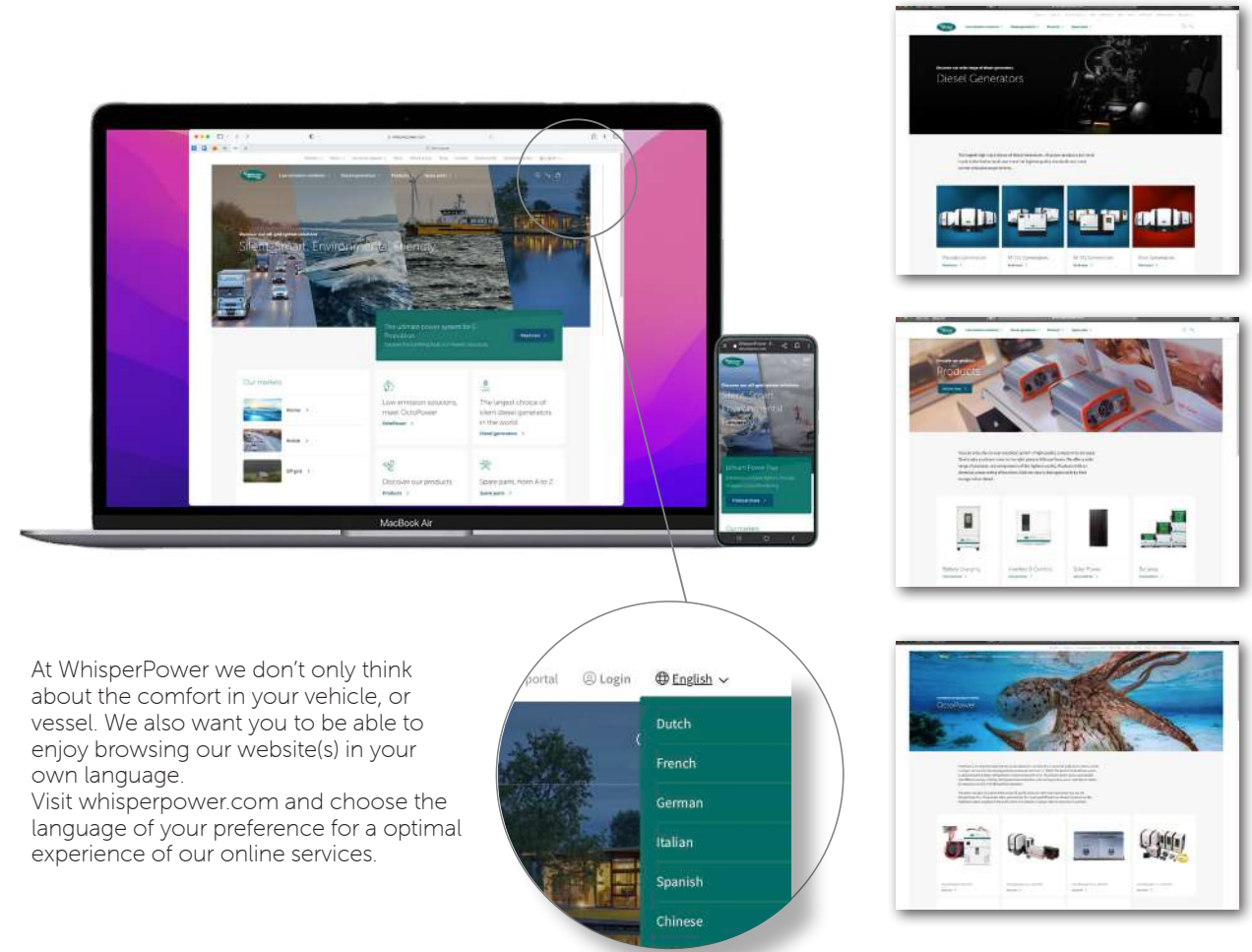









At WhisperPower we don't only think about the comfort in your vehicle, or vessel. We also want you to be able to enjoy browsing our website(s) in your own language. Visit whisperpower.com and choose the language of your preference for an optimal experience of our online services.

Staff and dealers Corporate Wear

Polo shirts, caps, jackets and more can be purchased by our distributors. For more information send us an email to sales@whisperpower.com



-  International
-  Benelux
-  Germany
-  United Kingdom
-  Spain & Portugal
-  China
-  Pacific
-  Americas

Distribution in over 50 countries



Your dealer:



Enjoy Green Energy

T: +31 512 571 550 | sales@whisperpower.com | whisperpower.com